

# Brand guidelines



# Gurtam corporate identity guide. Contents

---

## 01 — Strategy

Mission  
Brand idea  
Tone of voice  
Design approach

---

## 02 — Logo

Logo  
Exclusion zone and scale  
Co-branding  
Logo and lock-up suite

---

## 03 — Color

Corporate color  
Percentage of colors  
Primary color  
Black & white  
Secondary color  
Color pairings

---

## 04 — Typography

Corporate fonts  
Typeface settings  
Text color

---

## 05 — Iconography

Line icons  
Fill icons

---

## 06 — Animation

Text animation setting  
Path animation setting

---

## 07 — Corporate identity

Concept  
Corporate pattern  
Corporate brand identity  
Employer brand identity

01

# Strategy

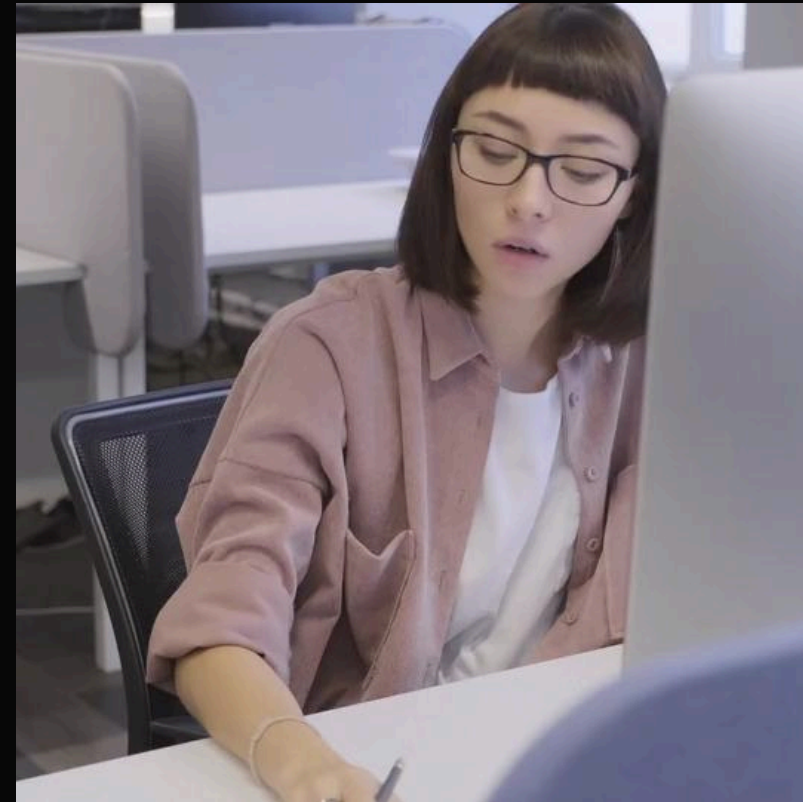

04  
05  
06  
07

Mission  
Brand idea  
Tone of voice  
Design approach

# Gurtam exists to bring telematics technology closer to people and businesses. We achieve this by developing and offering products that provide tangible value, enhanced decision-making, and business optimization.

---

## Corporate brand values

Expertise  
Team  
Products  
Community

## Employer brand values

Connection  
Empowerment  
Teamwork  
Meaning  
Vibe

# Brand idea

---

## For customers

Gurtam is a trusted and renowned provider of telematics software solutions enabling functional and reliable ways to connect businesses, their fleets, and machines.

---

## For employees

Gurtam is a company with the best features of corporations and IT startups; it encourages a creative process of development solutions that create impact as they are aimed to make the world more efficient, more connected, and safer.

# Tone of voice

**Respectful and humane**  
**Professional and confident**  
**Crisp and clear**  
**Positive**

# Design approach

---

## Corporate design approach

well-adjusted  
precise  
restrained  
trustworthy  
stylish

---

## Employer design approach

bold  
bright  
contrasting  
emotionally engaging  
vivid

02

Logo

09

10

11

13-15

Logo

Exclusion zone and scale

Co-branding

Logo and lock-up suite



**Warning!**

You cannot separate one from the other, place one below the other, change the distance

**Exceptions:**

- the symbol and the wordmark can get separated if the logo requires physical reproduction in a small area (embroidery, engraving, metal printing, etc)
- when the symbol is used as an avatar or favicon
- when the symbol or the wordmark make up an artistic idea (fantasy souvenir, photo zone, etc)

# Exclusion zone and scale

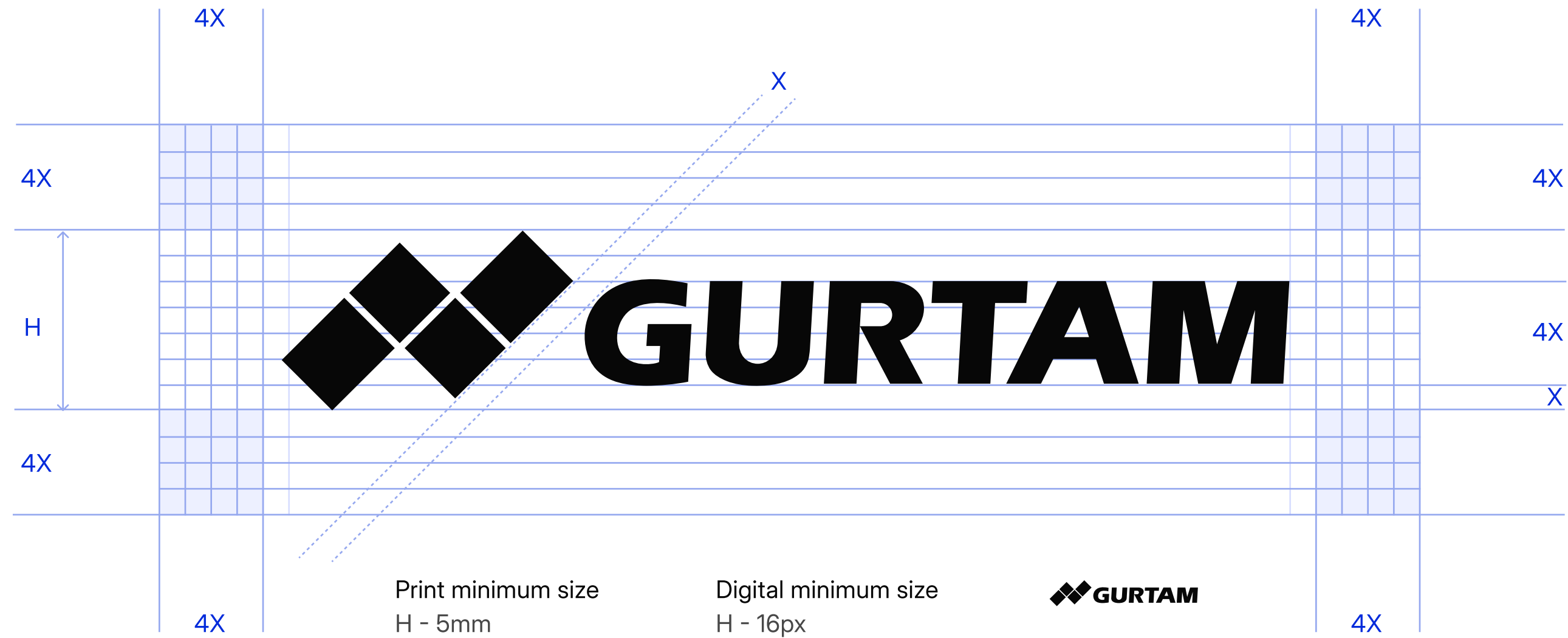

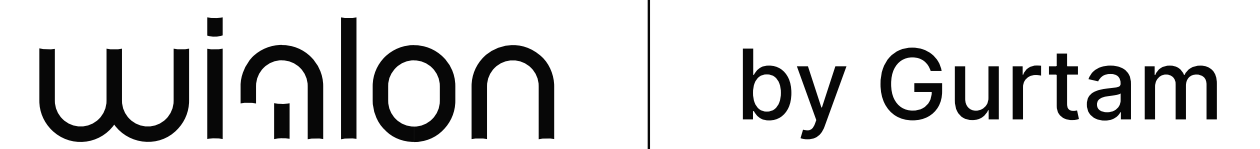
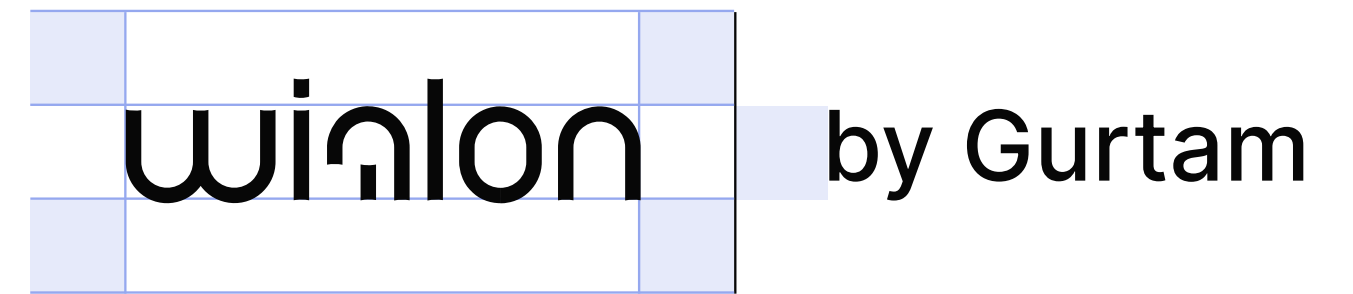

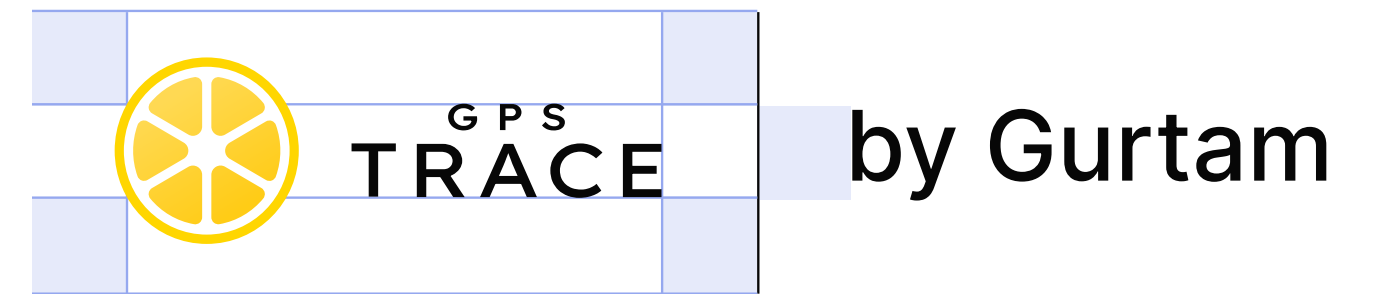
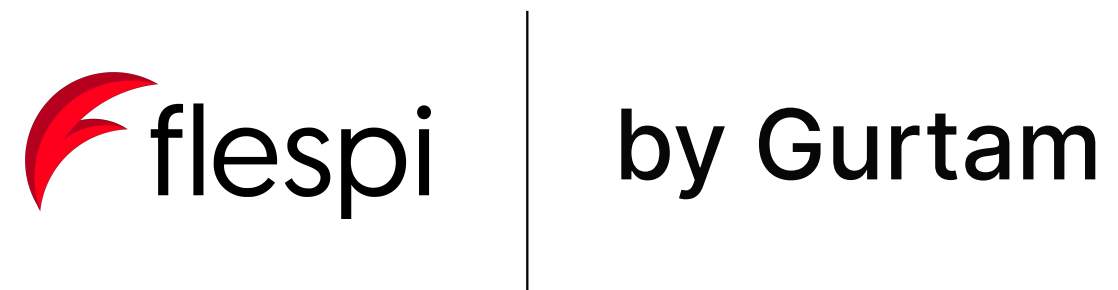
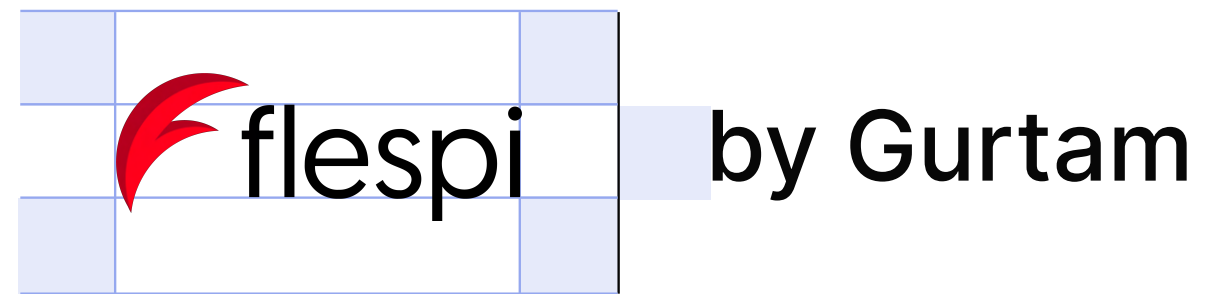

Logo corporate color lock-up suite







Logo



Brand guidelines



Gurtam

03

# Colors

17

18-19

20

21

22-24

25

Corporate colors

Color hierarchy

Primary color

Black & white

Secondary colors

Color pairings

<p>● 9.16 AAA AAA ○ 2.29</p> <p><b>Primary Blue 75</b> #96a8f0 rgb (150, 168, 240) cmyk (42, 29, 0, 0) Pantone 2716 C</p>	<p>● 2.35 ○ 8.92 AAA AAA</p> <p><b>Primary Blue 300</b> #002adb rgb (0, 42, 219) cmyk (94, 76, 0, 0) Pantone 2728 C</p>	<p>● 1.49 ○ 14.08 AAA AAA</p> <p><b>Primary Blue 500</b> #0A1E4C rgb (10, 30, 76) cmyk (87, 61, 0, 70) Pantone 655 C</p>	<p>● 1.37 ○ 15.33 AAA AAA</p> <p><b>Primary Grey 500</b> #0F0F0F rgb (15, 15, 15) cmyk (0, 0, 0, 100) Pantone Black 6C</p>
<p>● 19.52 AAA AAA ○ 0</p> <p><b>Primary Grey 0</b> #FFFFFF rgb (255, 255, 255) cmyk (0, 0, 0, 0) Pantone (none)</p>	<p>● 13.69 AAA AAA ○ 1.53</p> <p><b>Accent Sky 300</b> #aed6f1 rgb (174, 214, 241) cmyk (36, 6, 2, 0) Pantone 290 C</p>	<p>● 14.97 AAA AAA ○ 1.40</p> <p><b>Accent Yellow 300</b> #ffd700 rgb (255, 215, 0) cmyk (1, 13, 93, 0) Pantone Yellow 012 C</p>	<p>● 7.93 AAA ○ 2.65</p> <p><b>Accent Red 300</b> #ff69b4 rgb (255, 105, 180) cmyk (0, 70, 0, 0) Pantone 231 C</p>

# Corporate brand. Color hierarchy in the composition

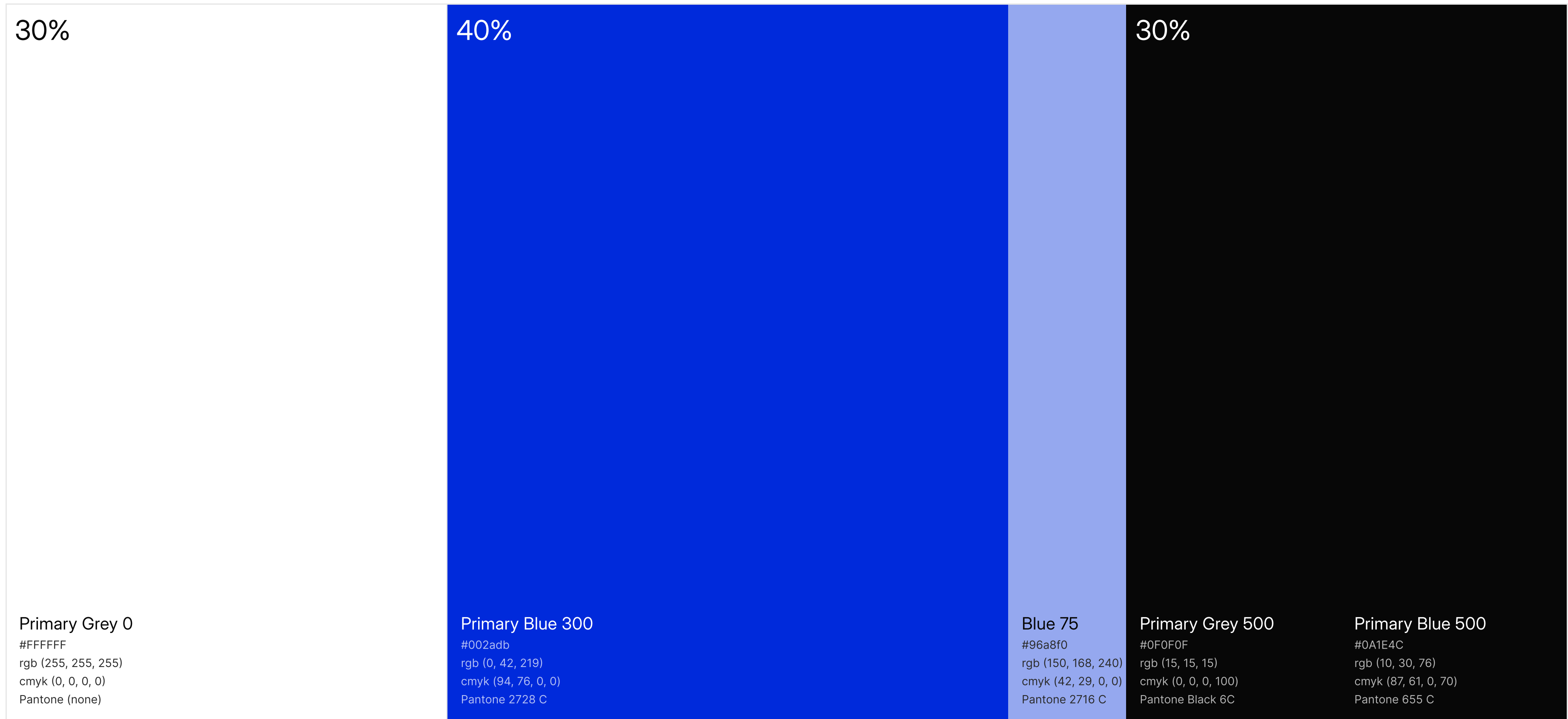

# Employer brand. Color hierarchy in the composition

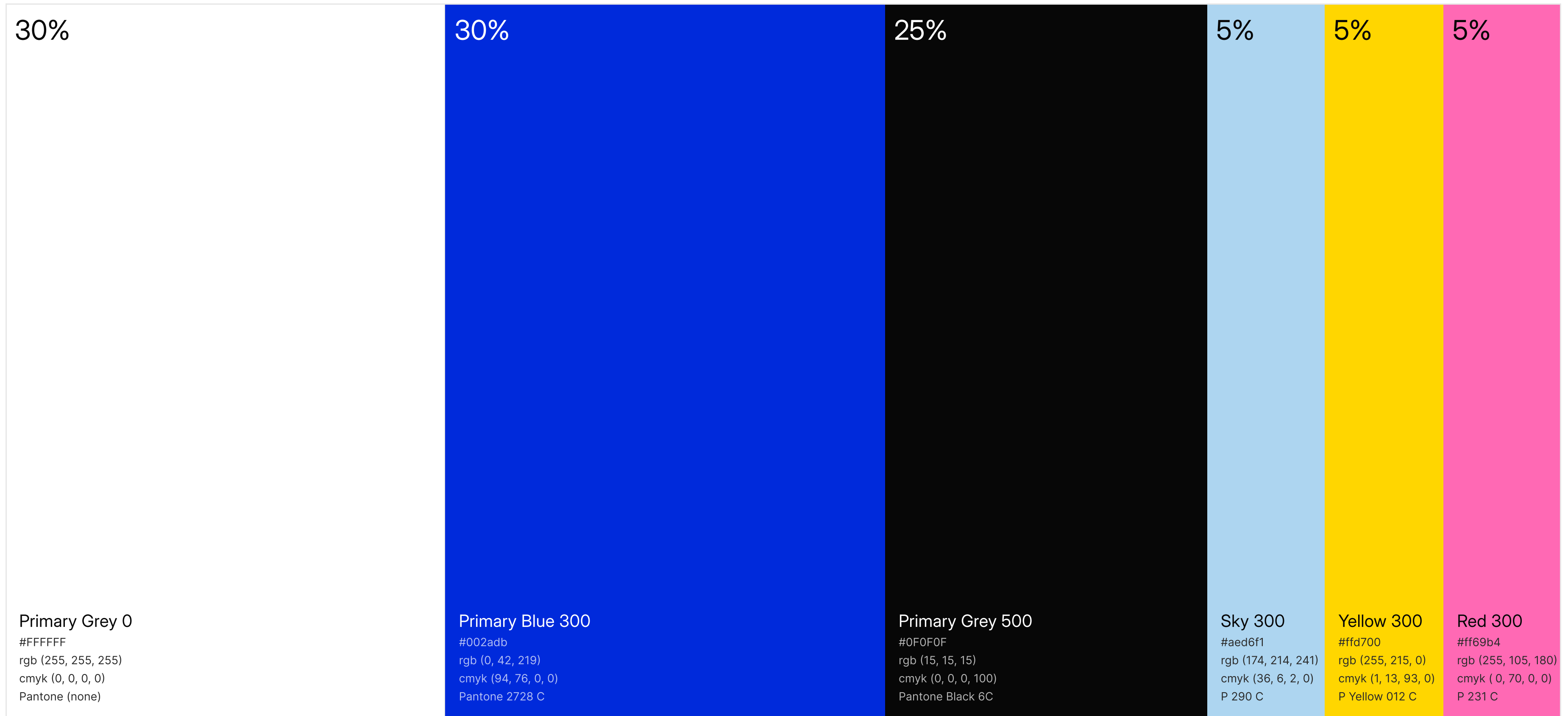

# Primary color | Blue

WCAG contrast: minimum - 4.5 AA, improved 7.1 AAA

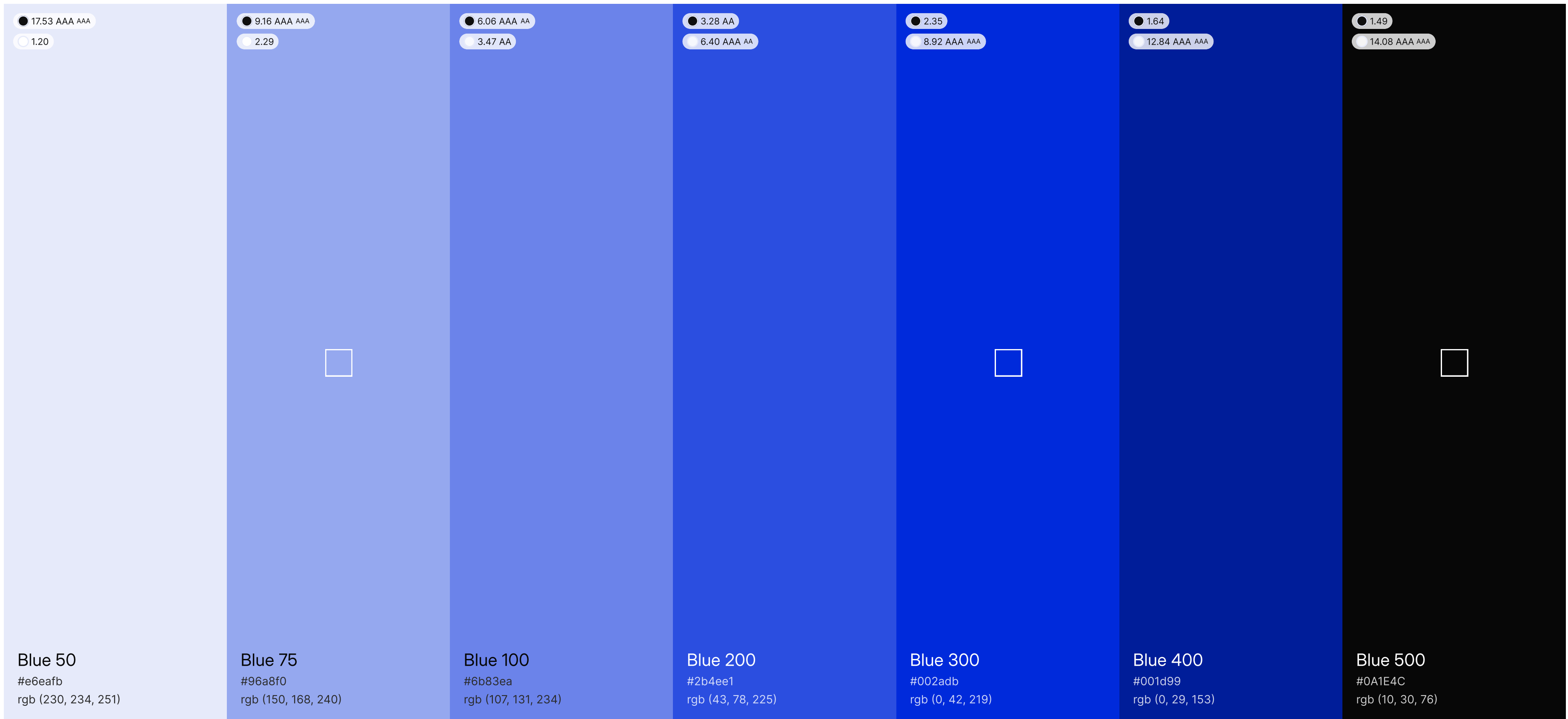

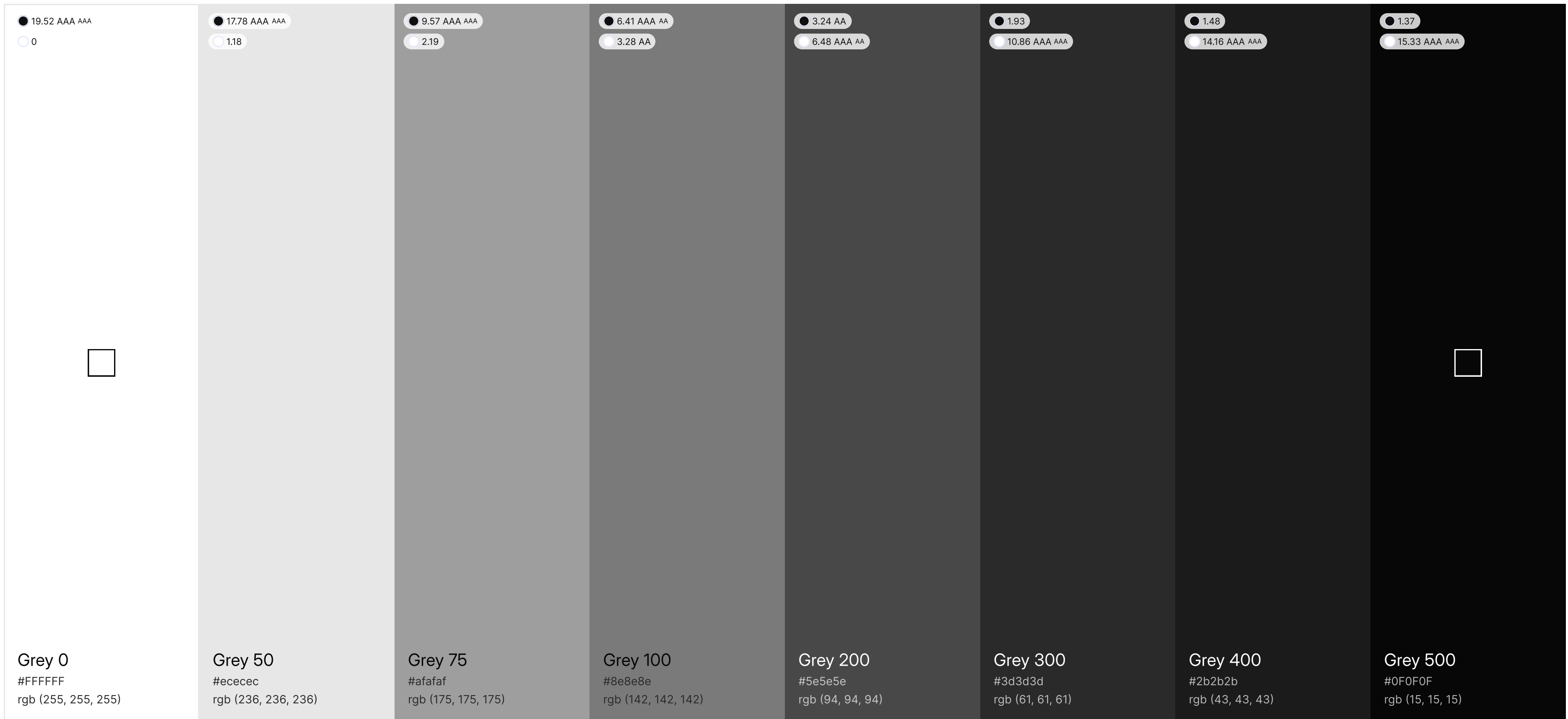

# Secondary color | Red

WCAG contrast: minimum - 4.5 AA, improved 7.1 AAA

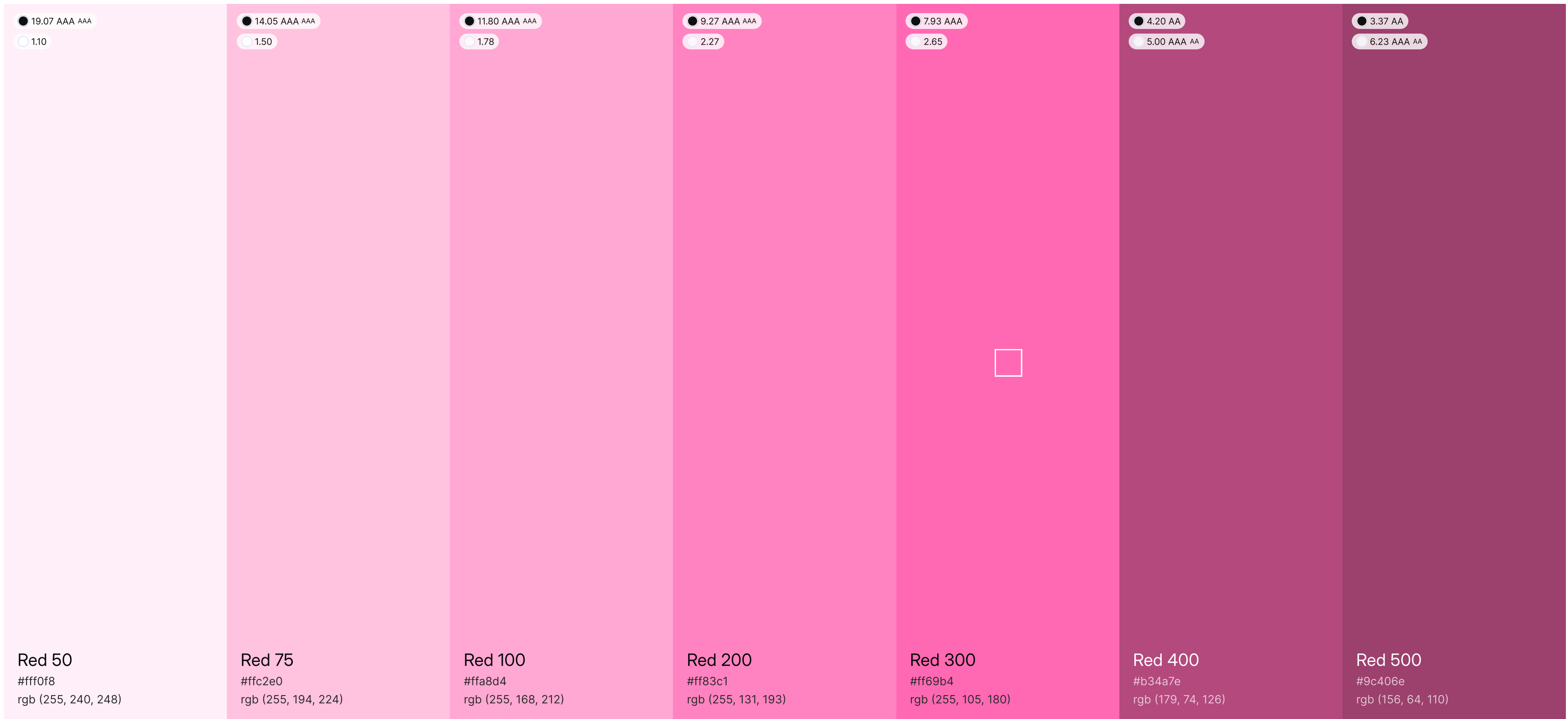

# Secondary color | Yellow

WCAG contrast: minimum - 4.5 AA, improved 7.1 AAA

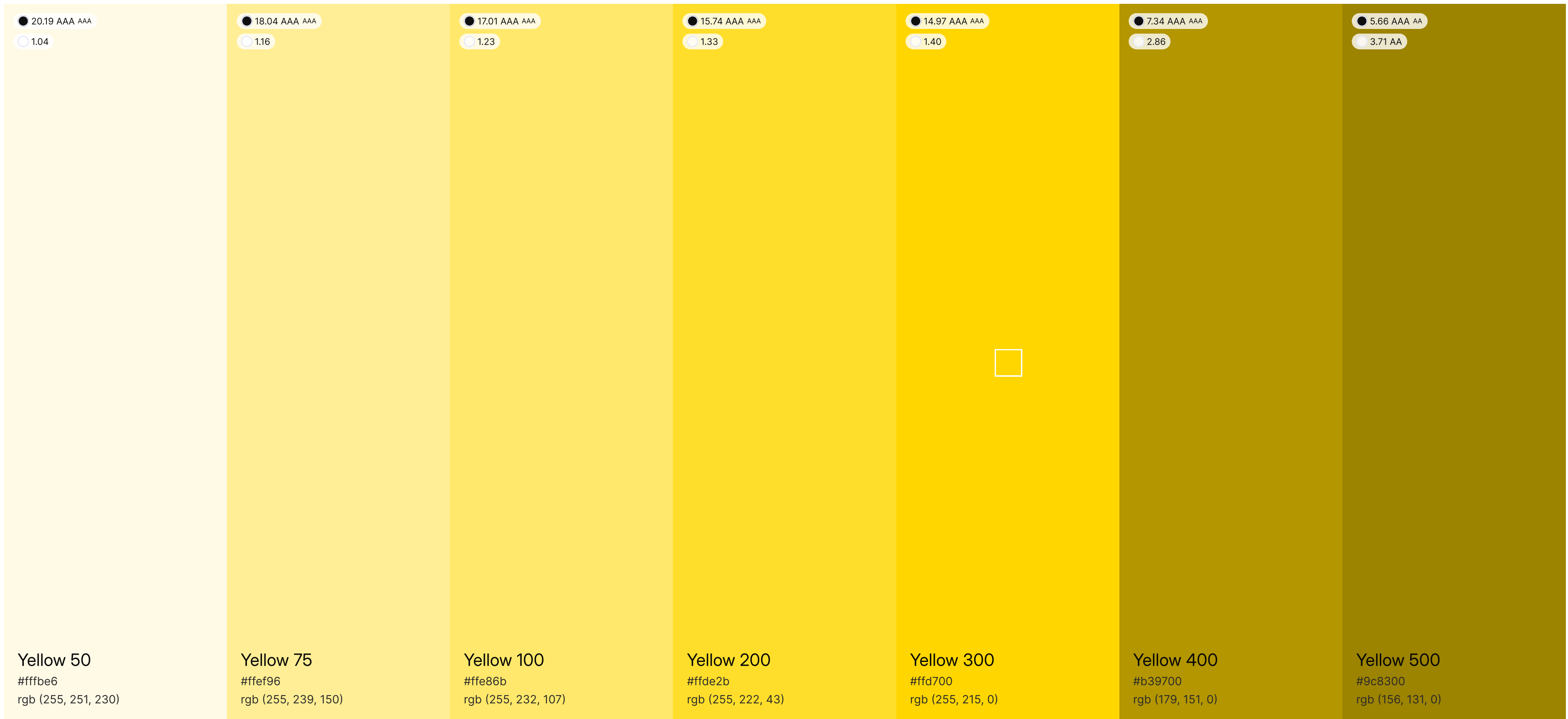

# Secondary color | Sky

WCAG contrast: minimum - 4.5 AA, improved 7.1 AAA

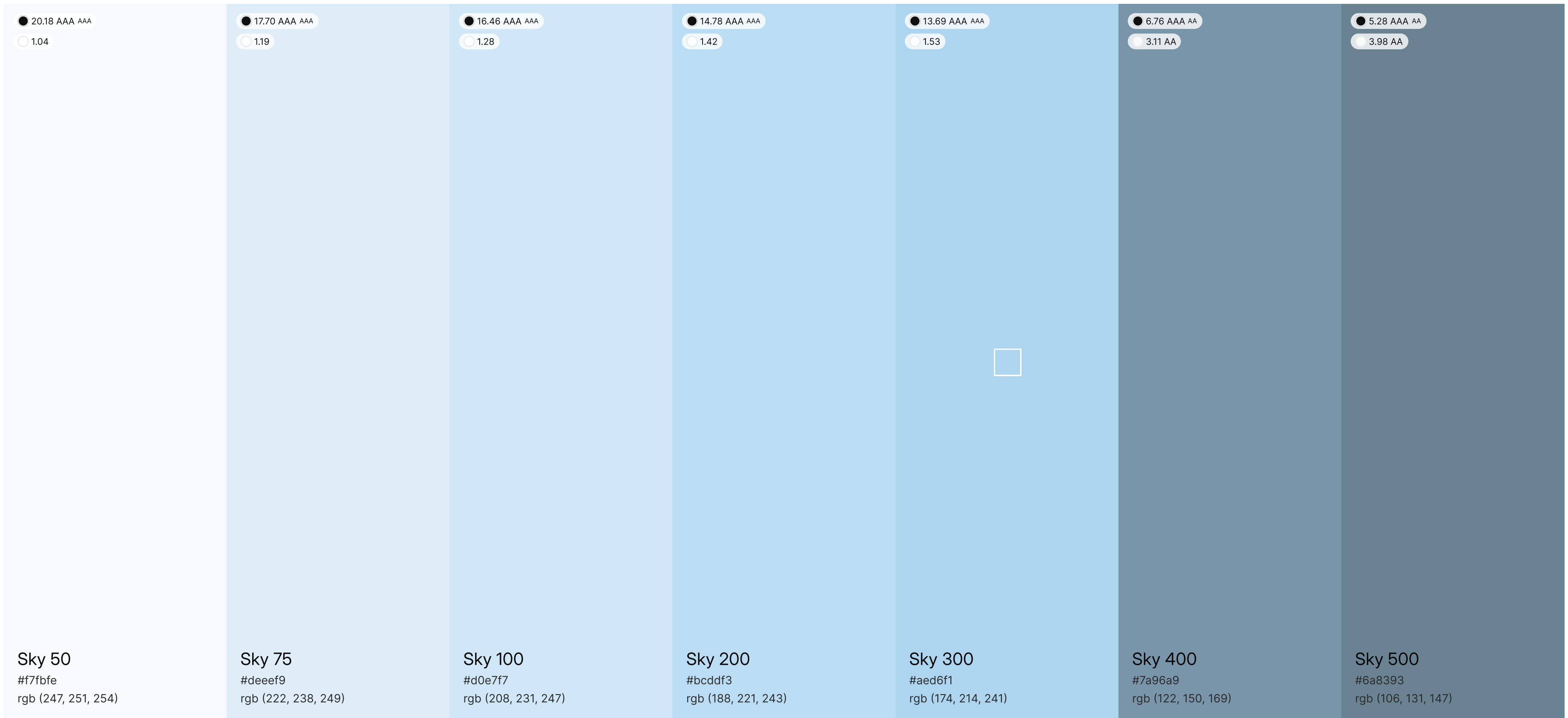

# Color pairings

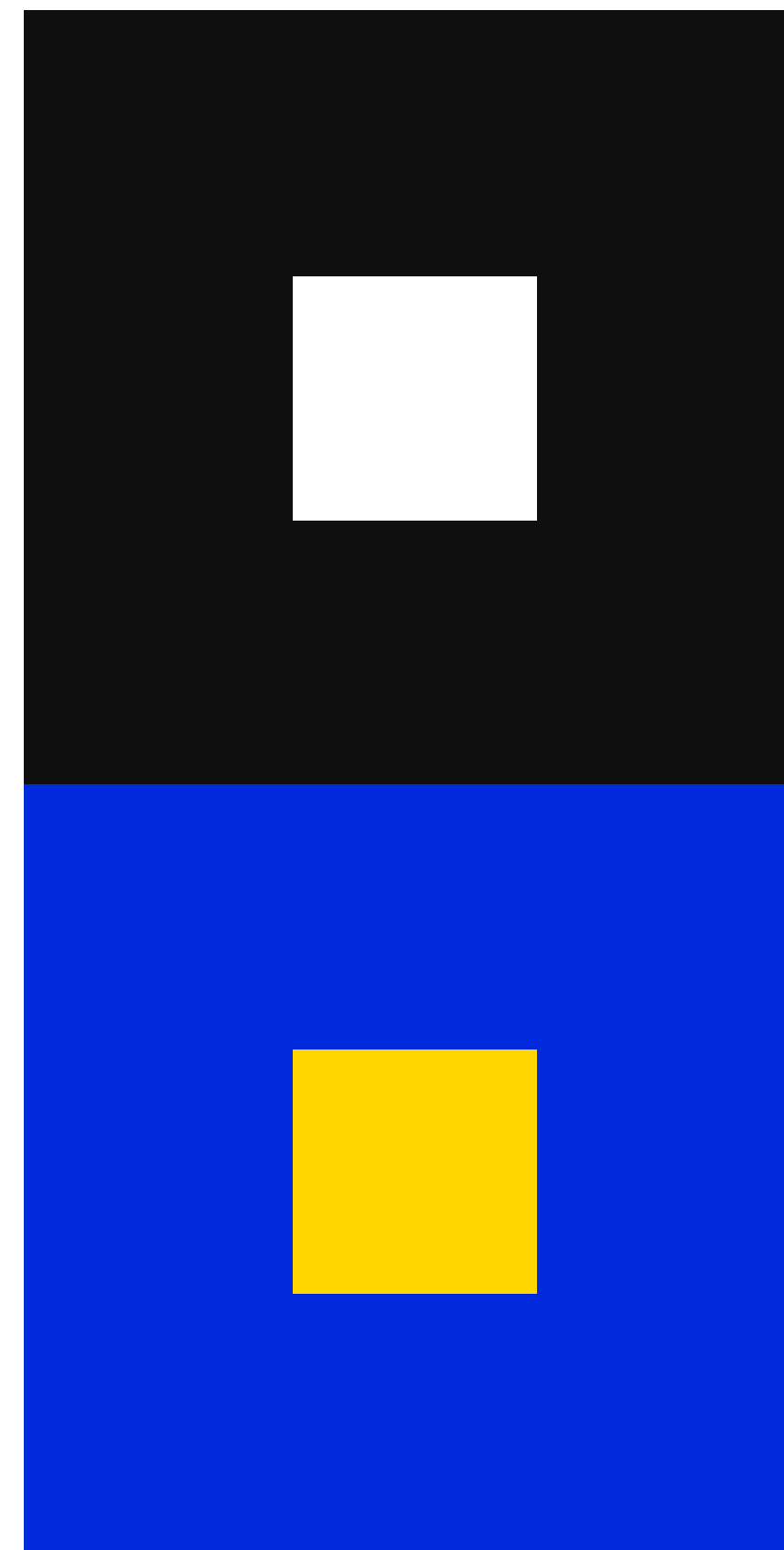
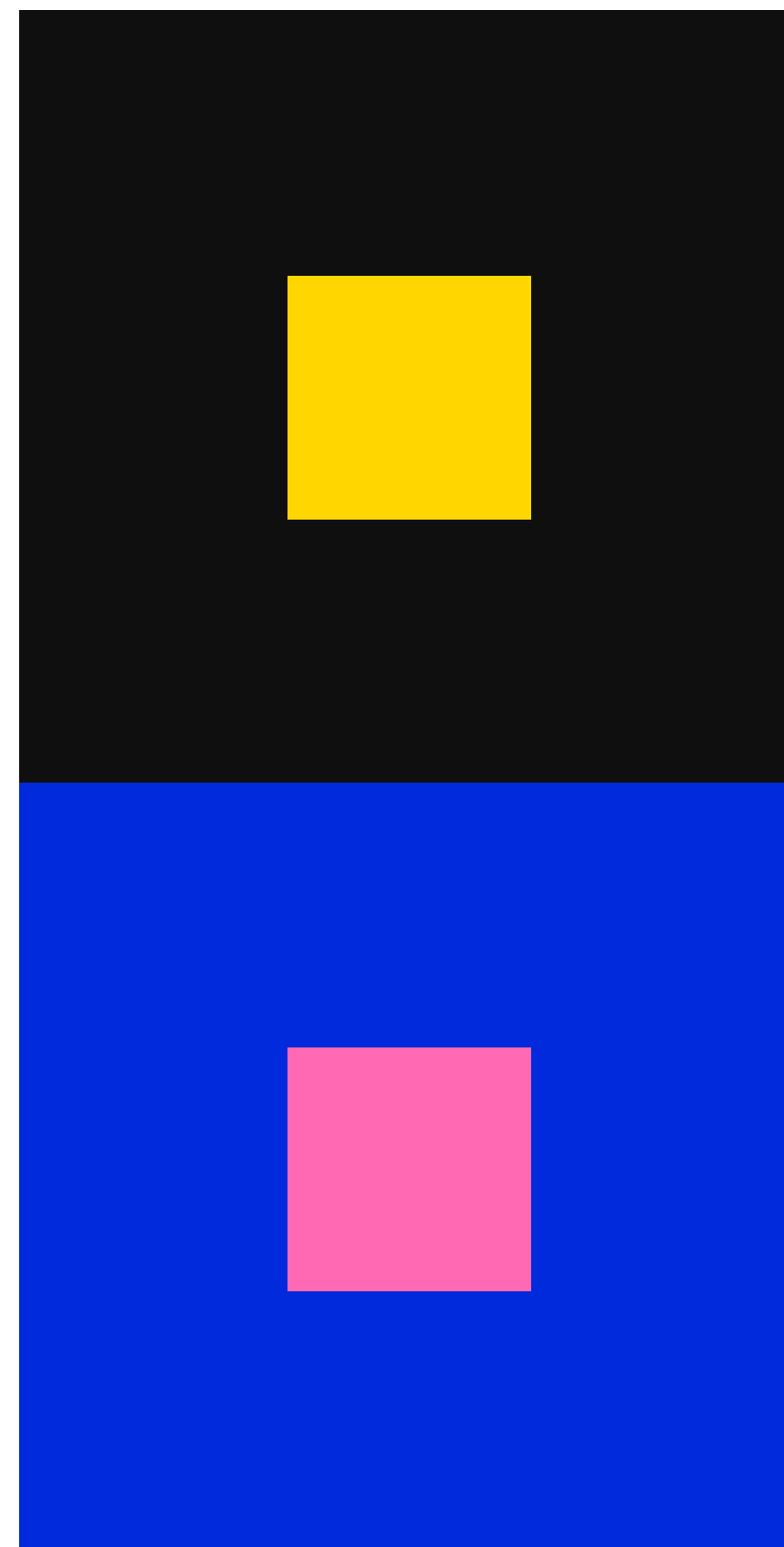
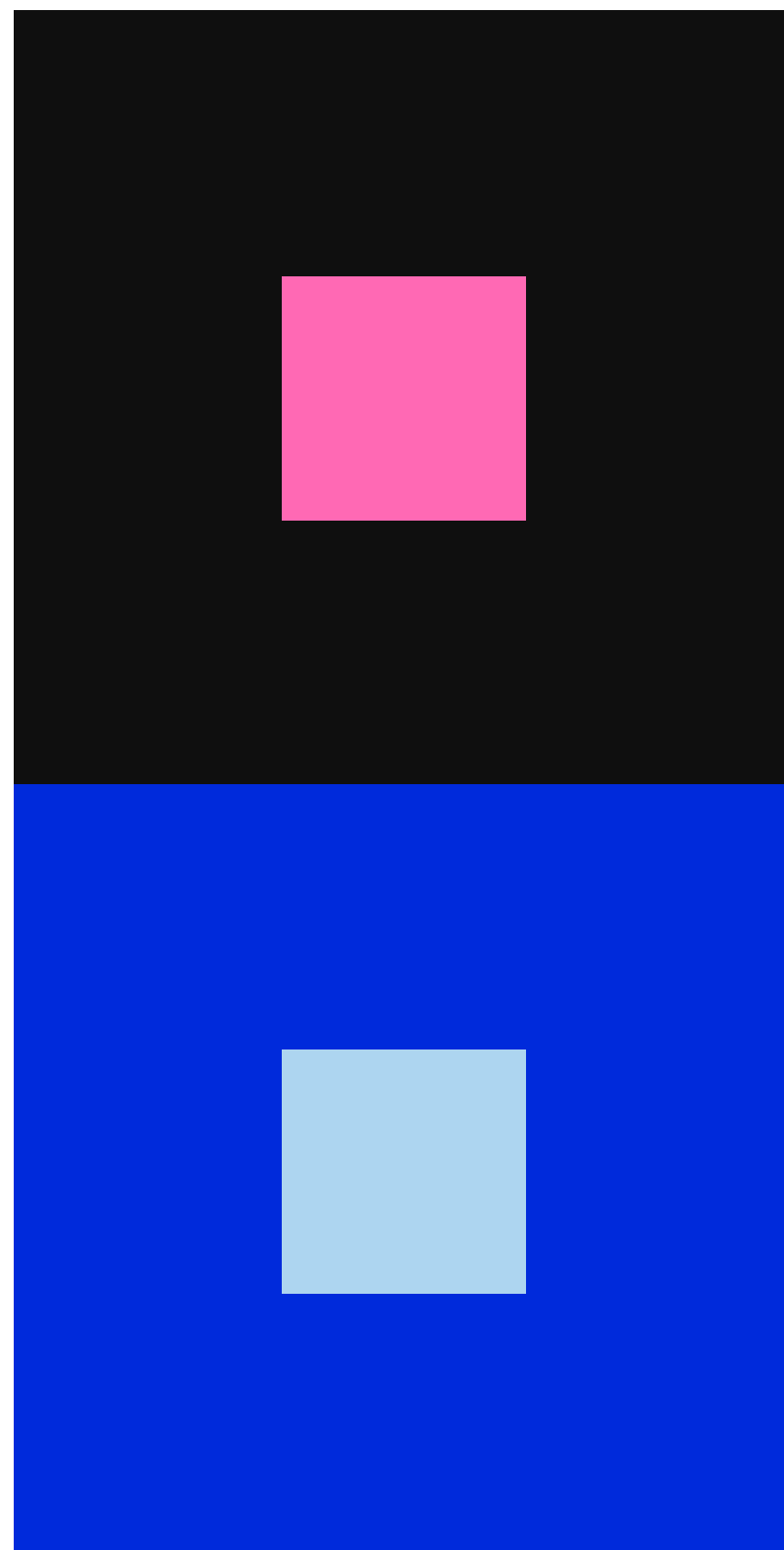
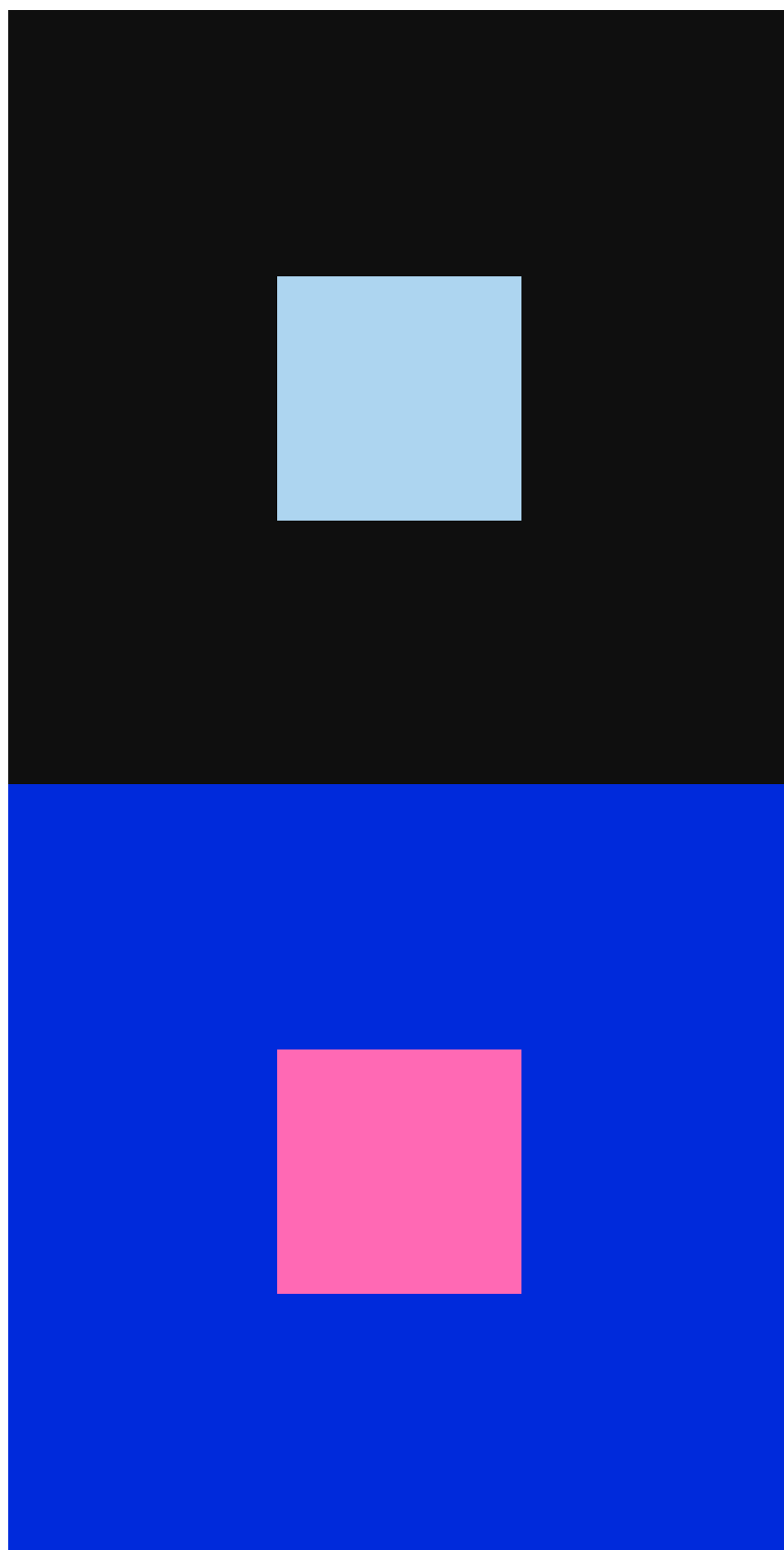

04

# Typography

27

28-29

30

Corporate fonts

Typeface settings

Text color

# Inter Display

Medium

ABCDEFGHIJKLMNOPQRSTUVWXYZ  
abcdefghijklmnopqrstuvwxyz  
0123456789!?.

Special symbol

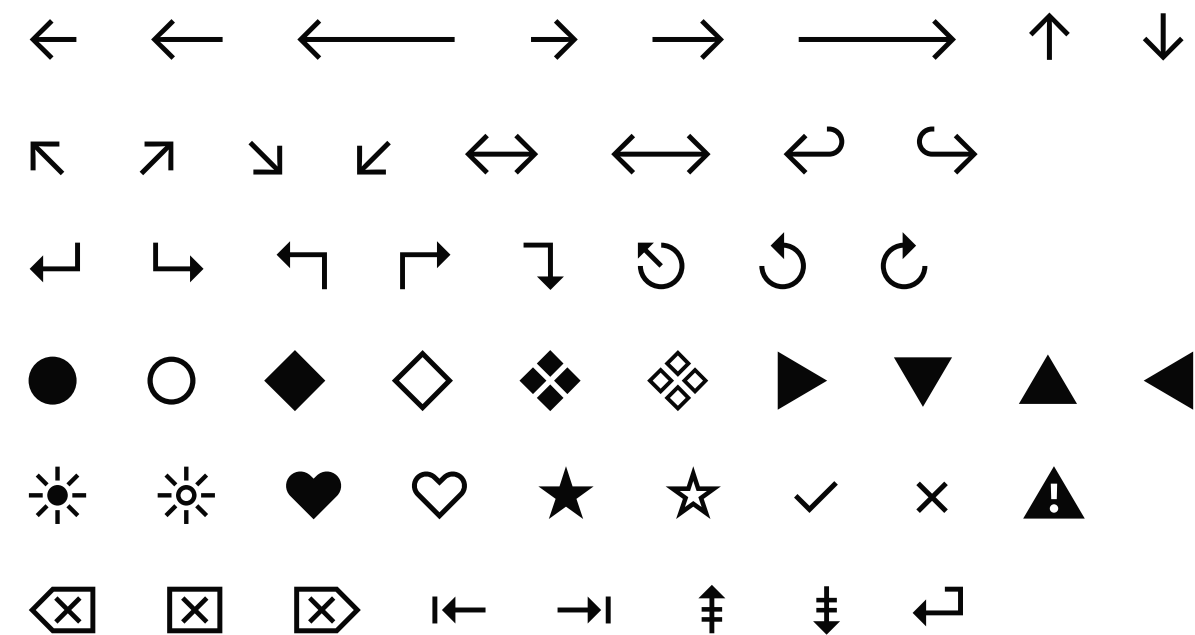

# Symbols

Regular

ABCDEFGHIJKLMNOPQRSTUVWXYZ  
abcdefghijklmnopqrstuvwxyz  
0123456789!?.

Special numbers

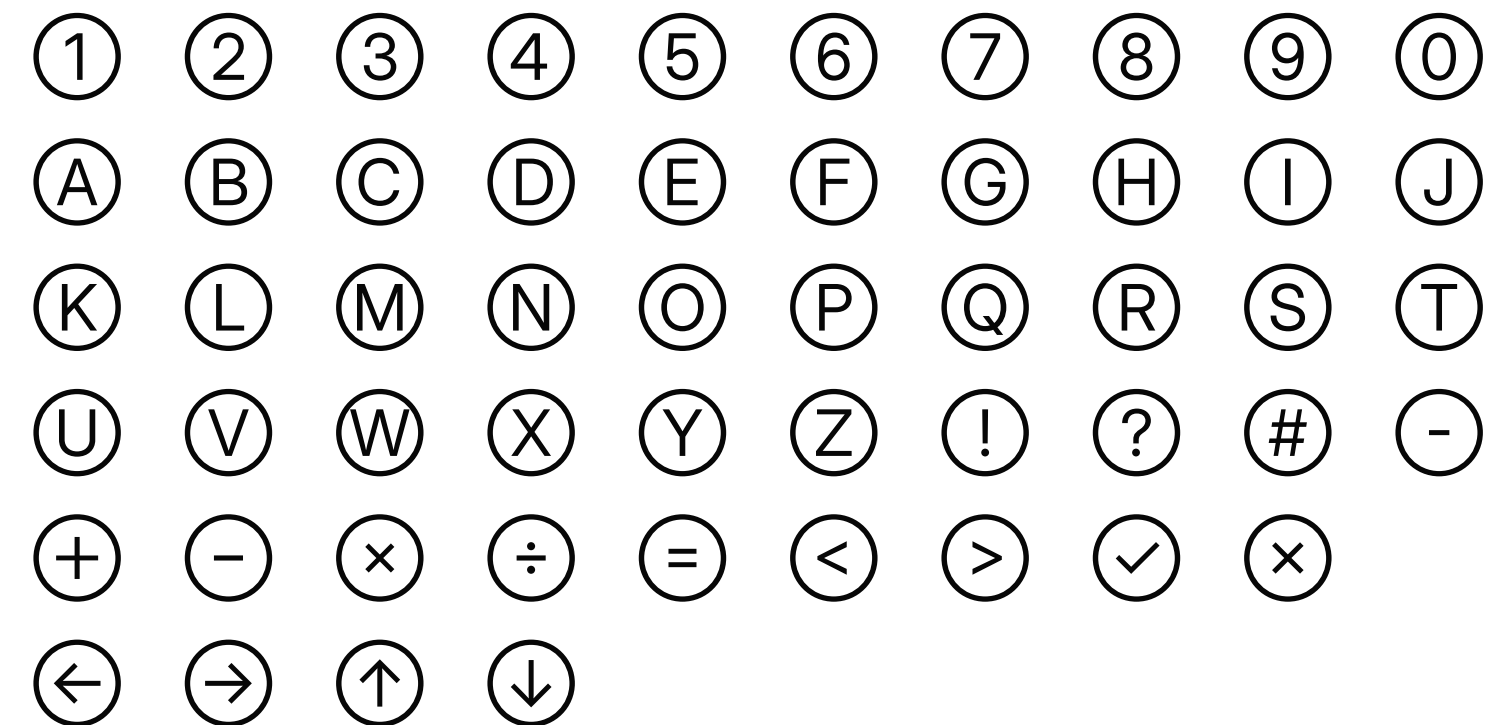

# Inter Display

# Screen settings

Digital minimum size 10-12px

Size	Line-height	Kerning	Tracking
00–16 px	140%	Metrics	1.2%
15–20 px	140%	Metrics	0.5%
20–32 px	130%	Metrics	-0.5%
32–44 px	120%	Metrics	-1.2%
44–72 px	100%	Metrics	-1.8%
72 px+	94%	Metrics	-2.0%

# Inter Display

# Print settings

Size	Line-height	Kerning	Tracking
00–16 pt	1,40	Metrics	1.2%
16–20 pt	1,40	Metrics	0.5%
20–32 pt	1,30	Metrics	-0.5%
32–44 pt	1,20	Metrics	-1.2%
44–72 pt	1,00	Metrics	-1.8%
72 pt+	0,94	Metrics	-2.0%

# Inter Display

# Color setting

White background

Blue background

Black background

■ Grey 500 Primary text

■ Grey 200 Secondary text

■ Grey 50 Outline

■ Grey 0 Primary text

■ 80% Grey 0 Secondary text

■ 20% Grey 0 Outline

■ Grey 0 Primary text

■ Grey 75 Secondary text

■ Grey 300 Outline

05

# Iconography

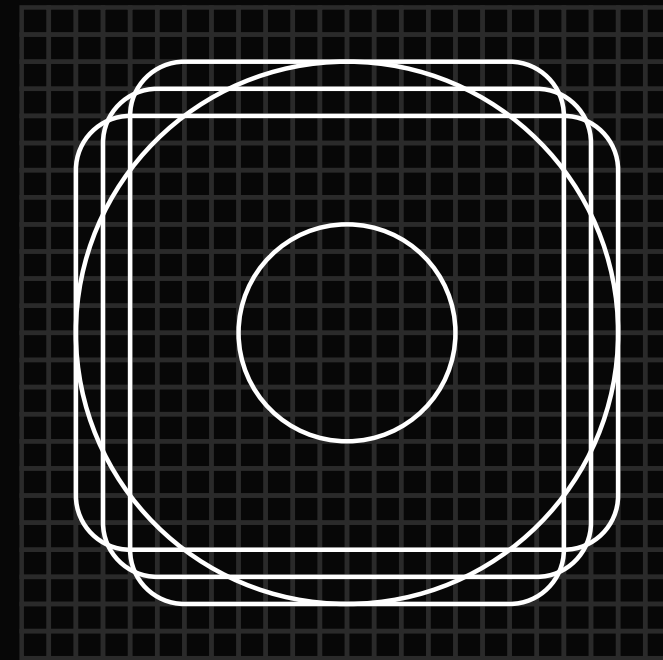

32

33

Line icons

Fill icons

# Icons

[See more](#)

Grid icon

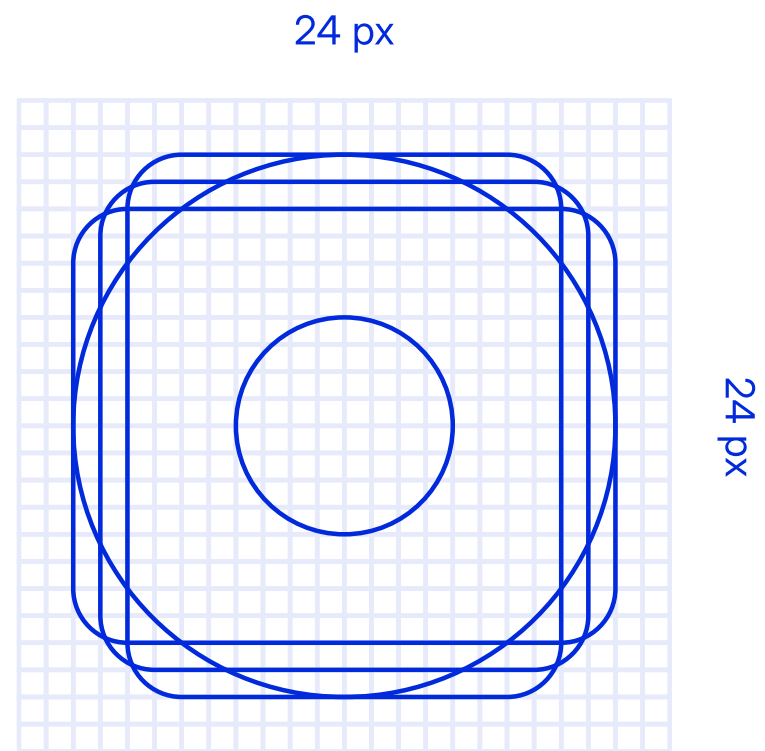

Material icon library

Weight 300

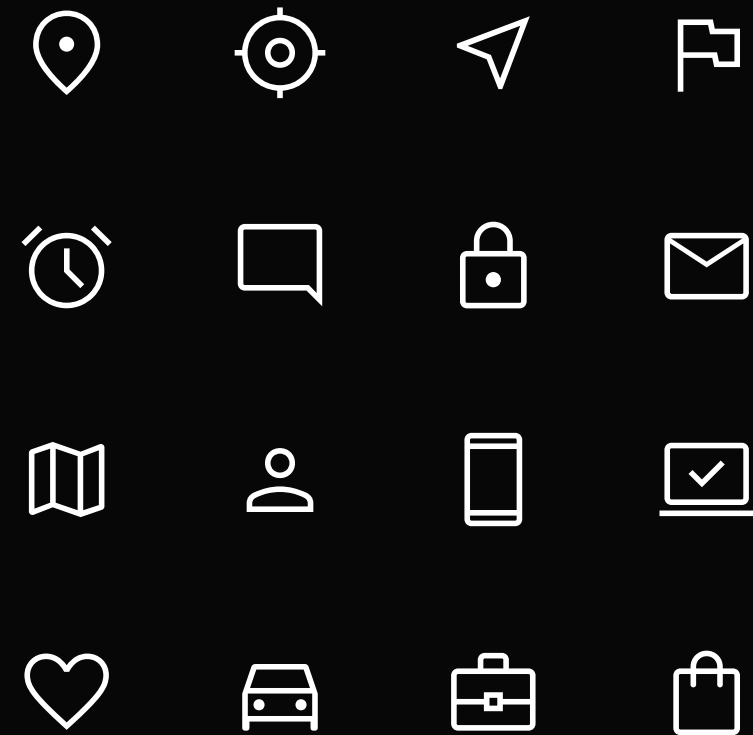

# Icons

[See more](#)

Grid icon

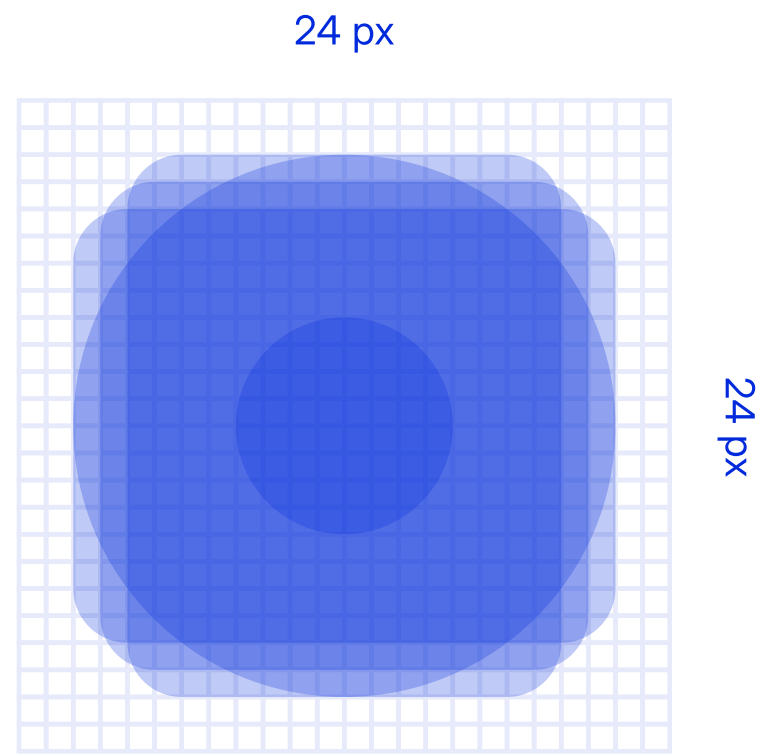

Material icon library

Fill

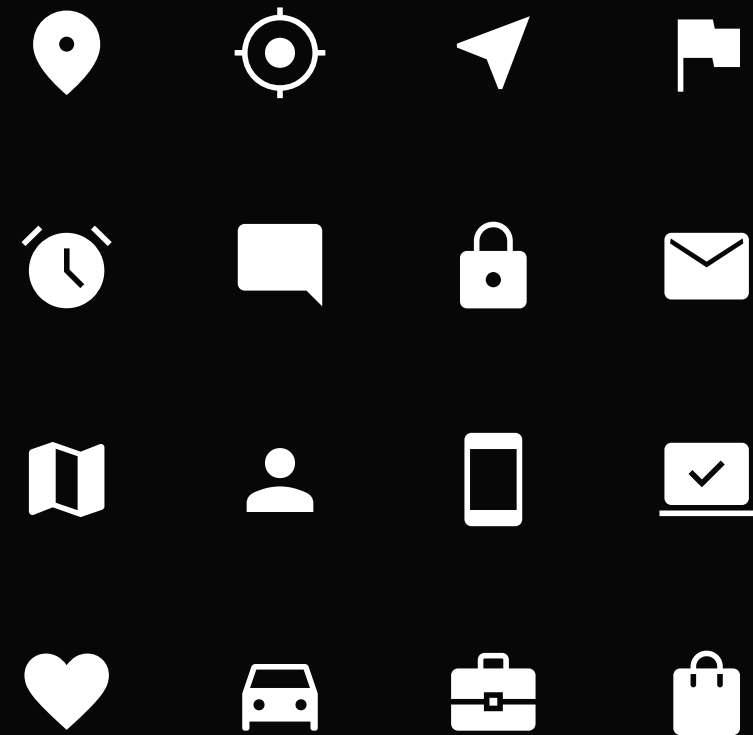

06

# Animation

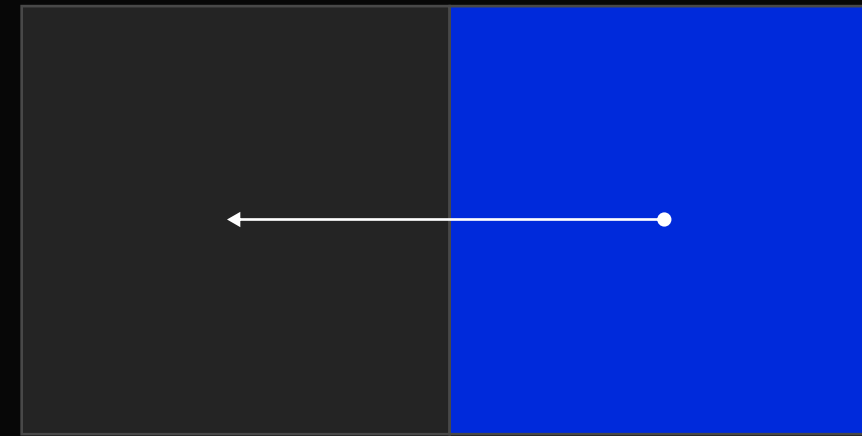

35

36

Text animation setting

Path animation setting

## Setting animation for heading

Animation of a line of text: cubic-bezier (1, 0, 0, 1); duration: 1200 ms;



Gurtam brings telematics to businesses

Word animation: cubic-bezier (1, 0, 0, 1); duration: 1200 ms;



**Gurtam** brings telematics to businesses

## Setting animation for path

Horizontal path animation

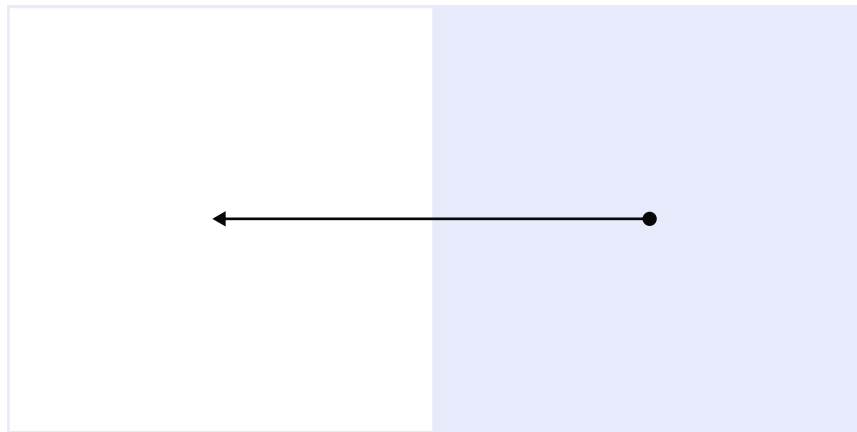

cubic-bezier (0.5, 0, 0, 1); duration: 1200 ms;

Vertical path animation

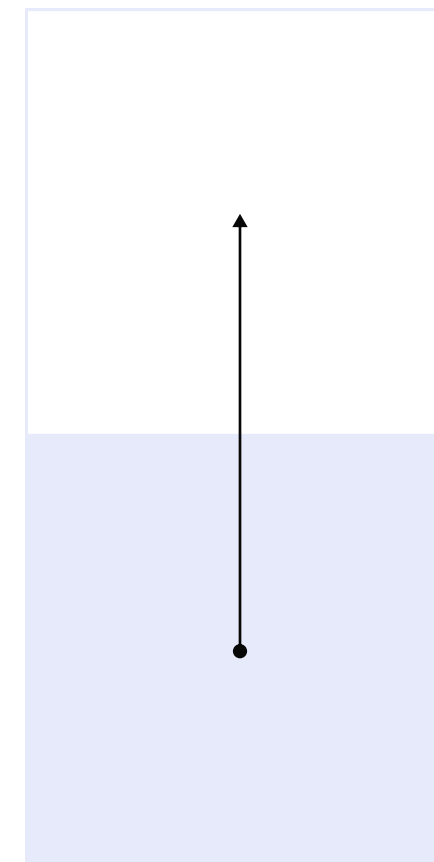

cubic-bezier (0.5, 0, 0, 1); duration: 1200 ms;

# Animation

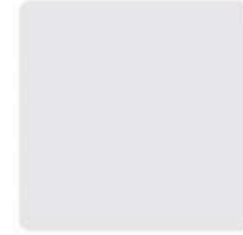

# Corporate identity



39

40

41-50



51-58

Concept

Corporate pattern

Corporate brand identity

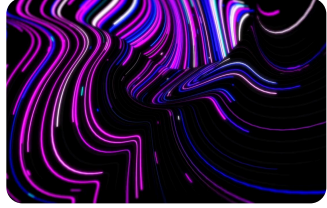
Employer brand identity

 The core concept of the brand identity is data.  Gurtam collects and transforms data for people and businesses. In design, a piece of data is represented by a square ■

# Corporate pattern

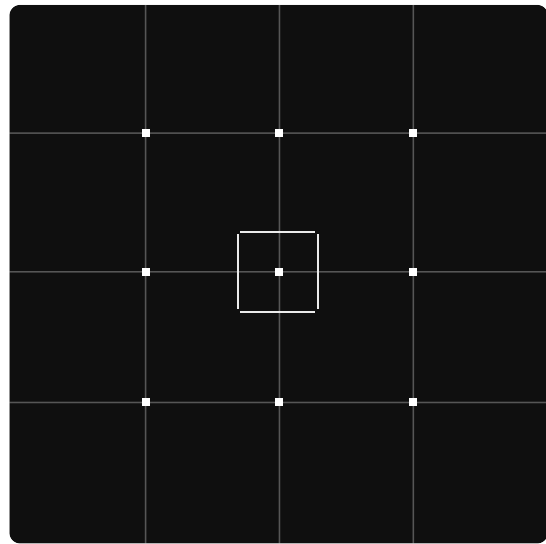

GPS grid pattern

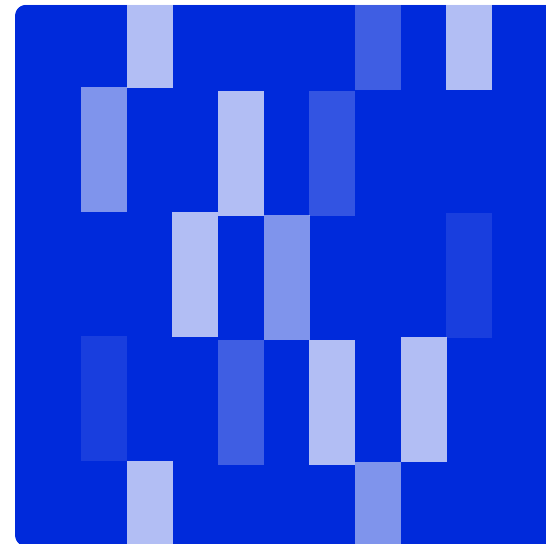

Data bit pattern

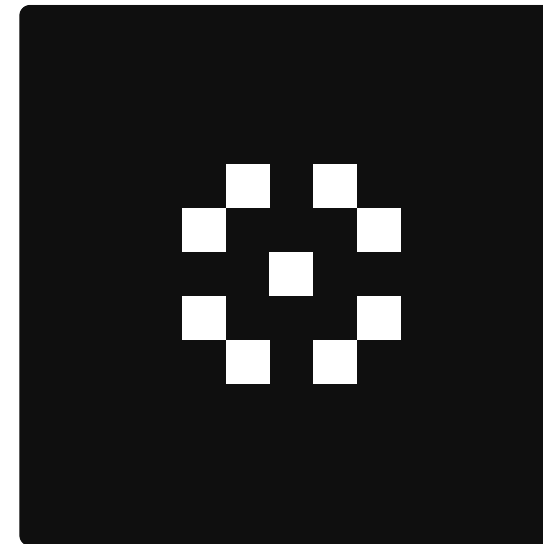

Technology ornament

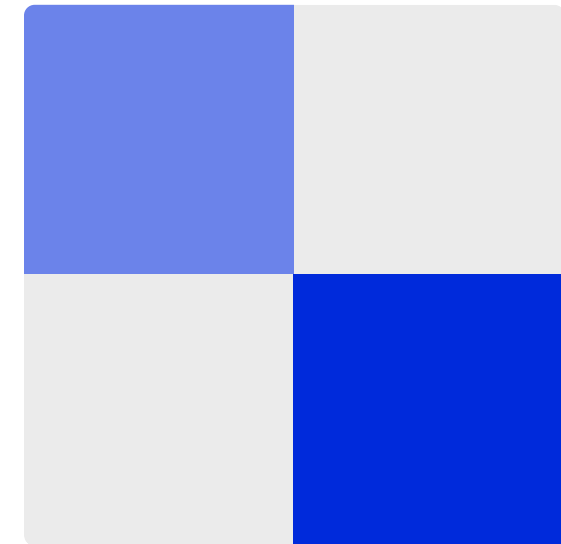

Corporate square

Corporate brand

# Art direction



The square is being introduced into all the company's media, changing them to fit the overall style. It is acceptable to use a 6 px border radius.



Corporate font

ABCDEFGHIJKLM  
MNOPQRSTUVWXYZ  
WXYZ  
Abcdefghijklmno  
pqrstuvwxyz  
0123456789!?.

Pattern

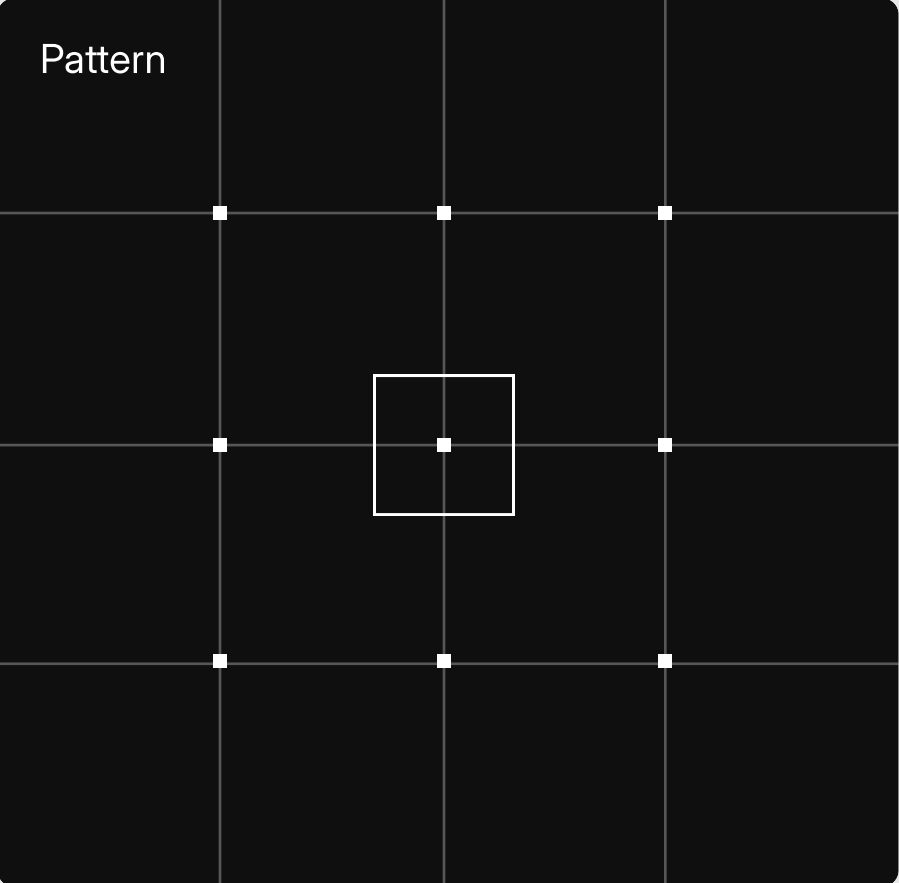

2 000 000  
Object



The square is being introduced into all the company's media, changing them to fit the overall style.

850+  
Partners



The square is being introduced into all the company's media, changing them to fit the overall style.

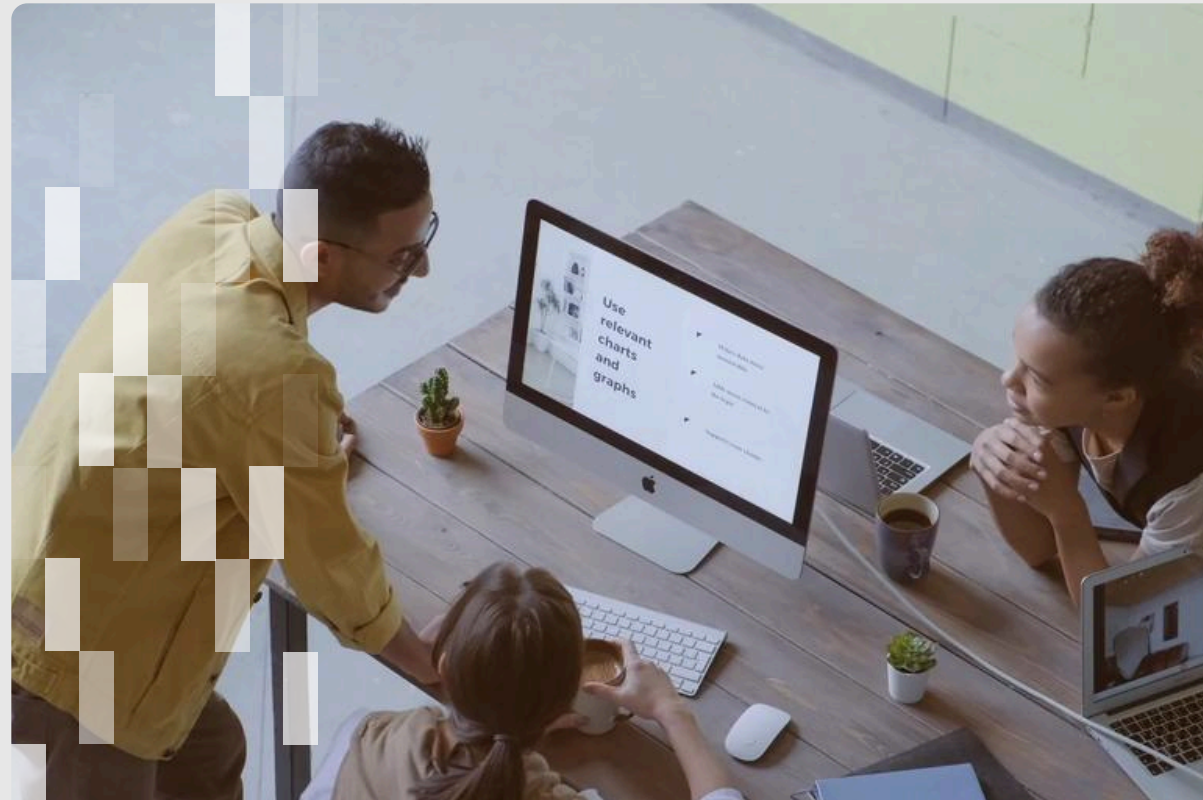

# Gurtam exists to bring telematics technology closer to people and businesses.

1

The square is being introduced into all the company's media, changing them to fit the overall style.

2

The square is being introduced into all the company's media, changing them to fit the overall style.

3

The square is being introduced into all the company's media, changing them to fit the overall style.

4

The square is being introduced into all the company's media, changing them to fit the overall style.



[www.gurtam.com](http://www.gurtam.com)

# Gurtam exists to bring telematics technology closer to people and businesses.

The square is being introduced into all the company's media, changing them to fit the overall style.

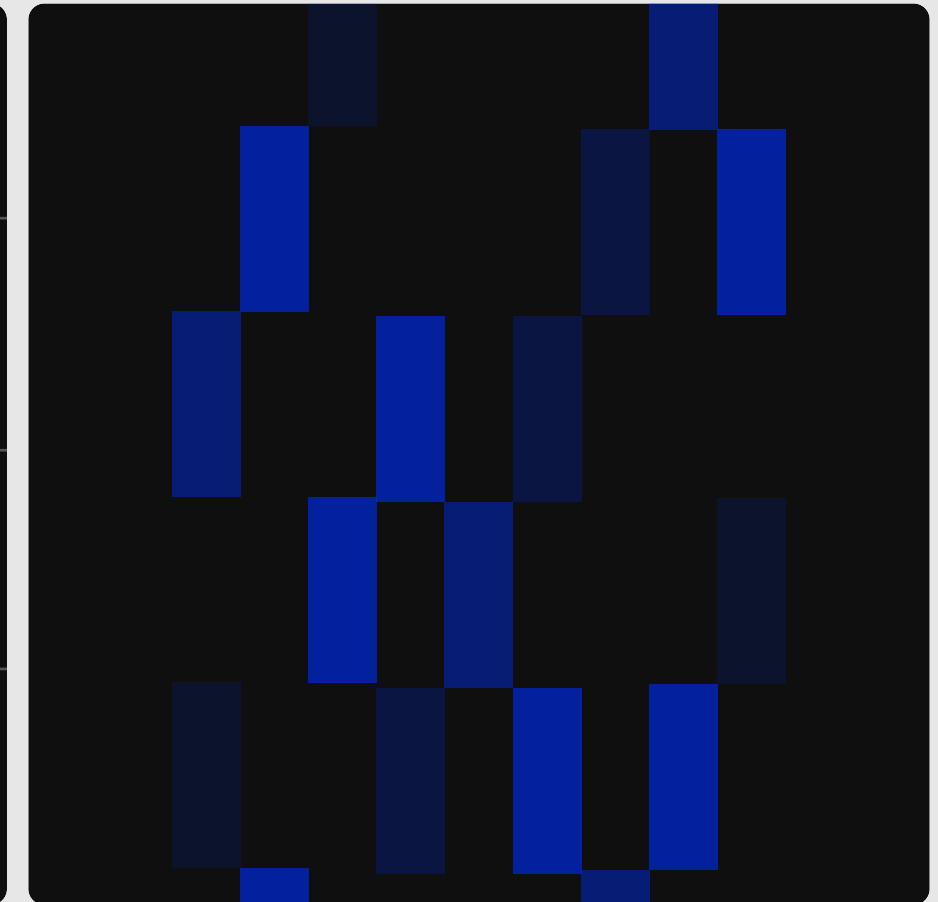
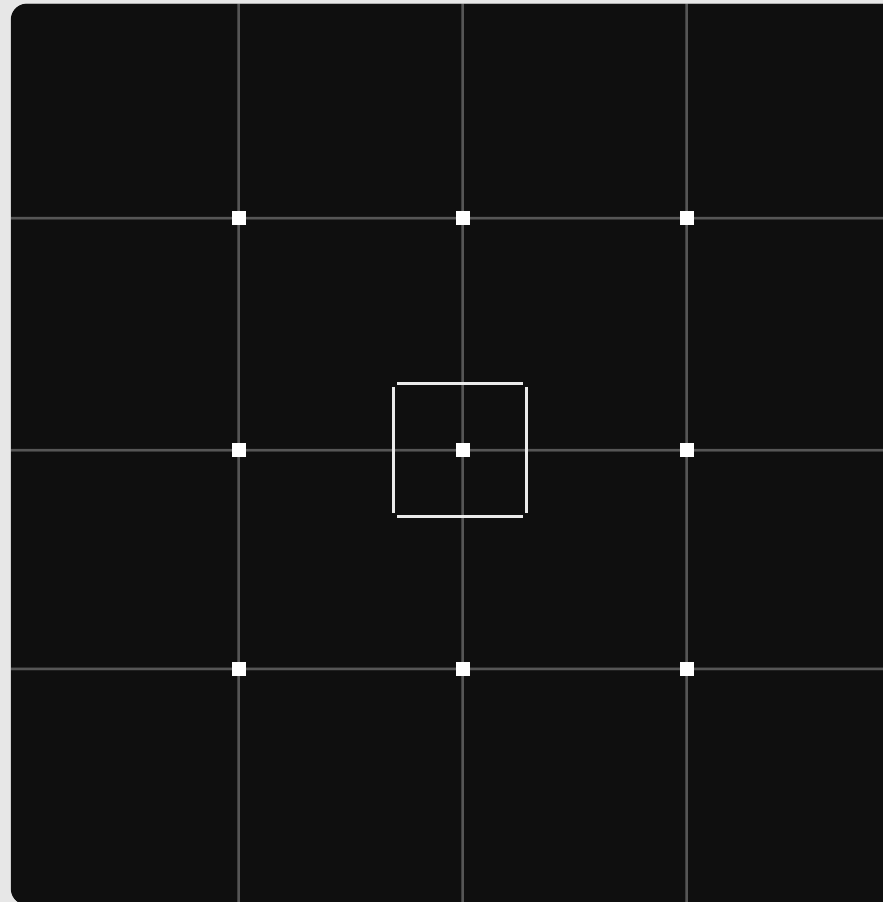

# Rules for grids

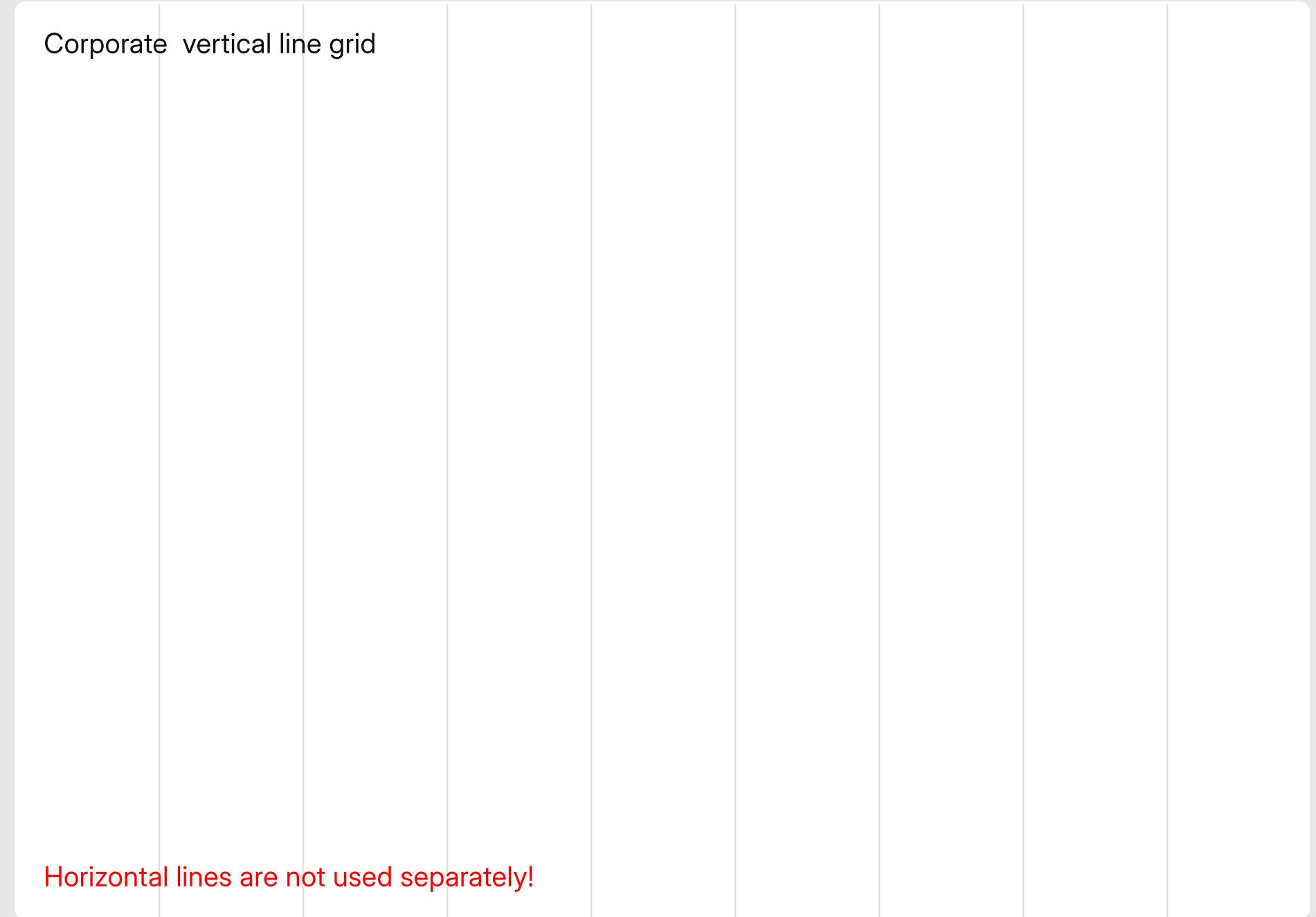
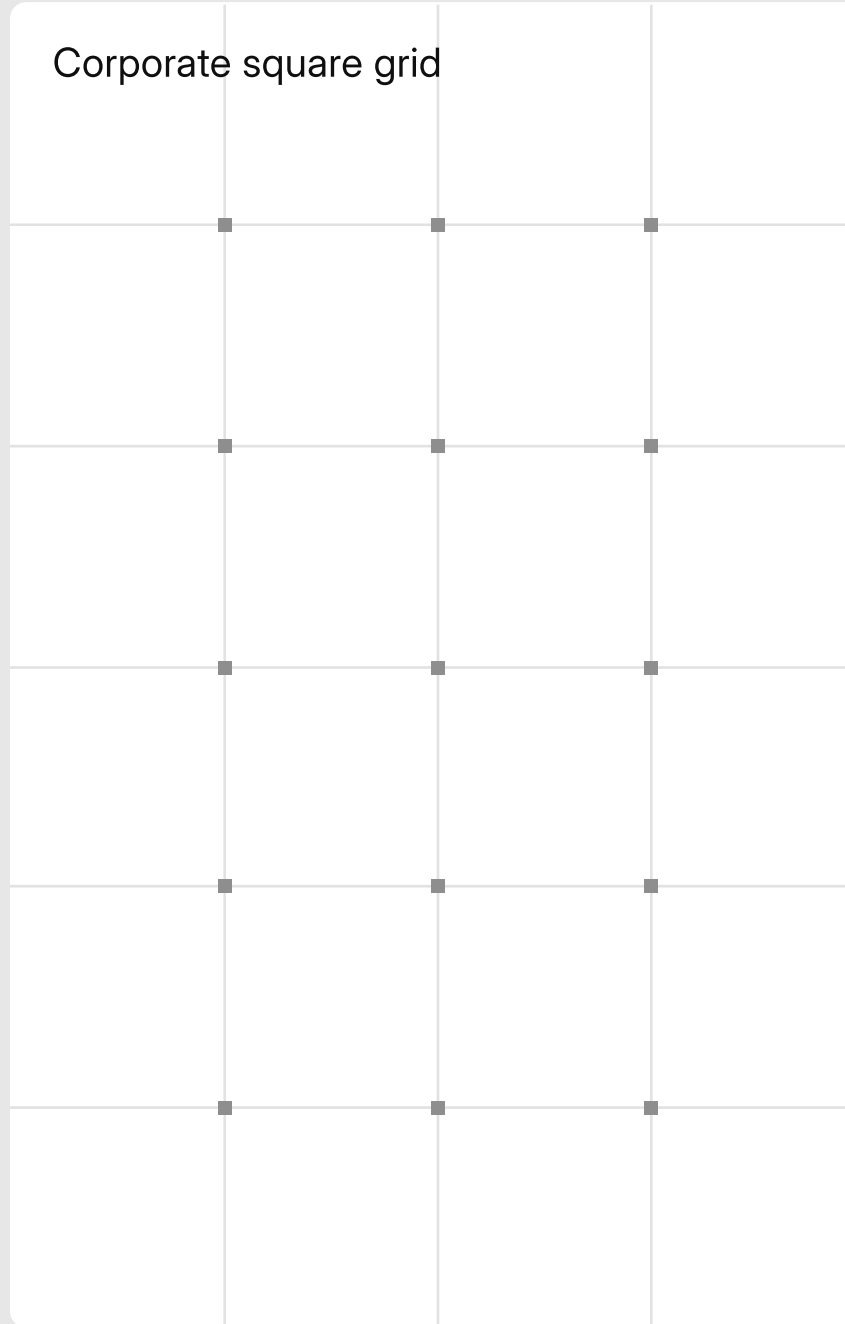
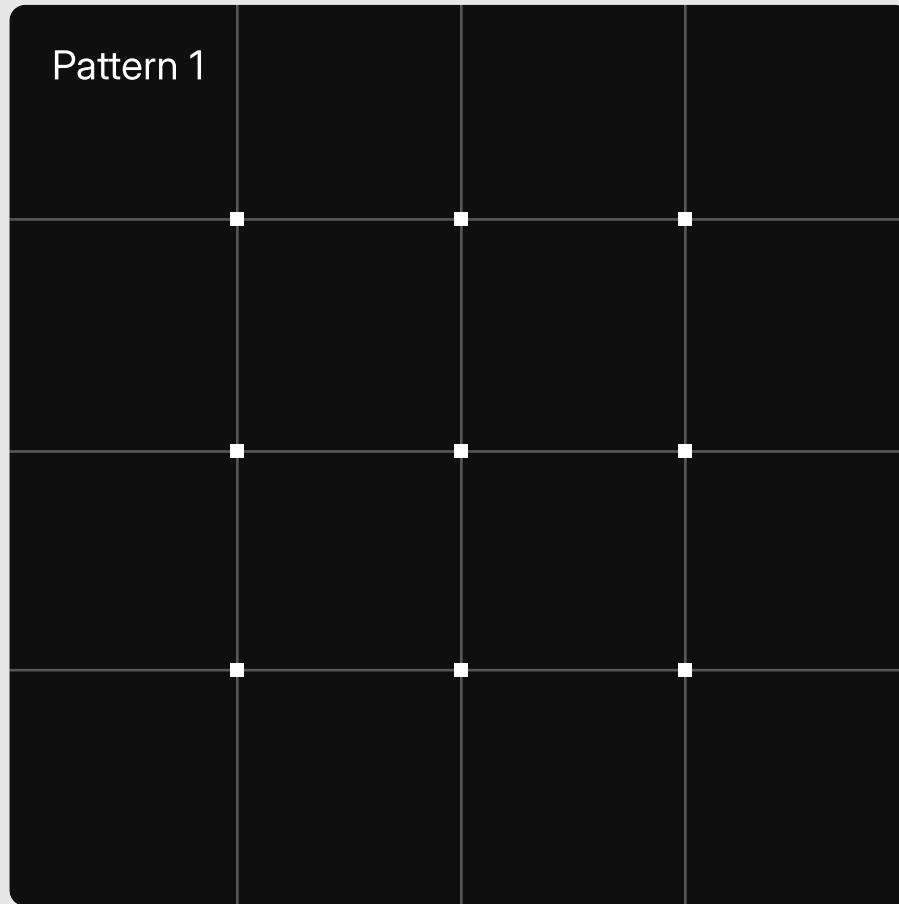

- White line color 12% #191919
- Black dot color #8E8E8E
- White line color 30% #FFFFFF
- White dot color #FFFFFF

# Color pattern

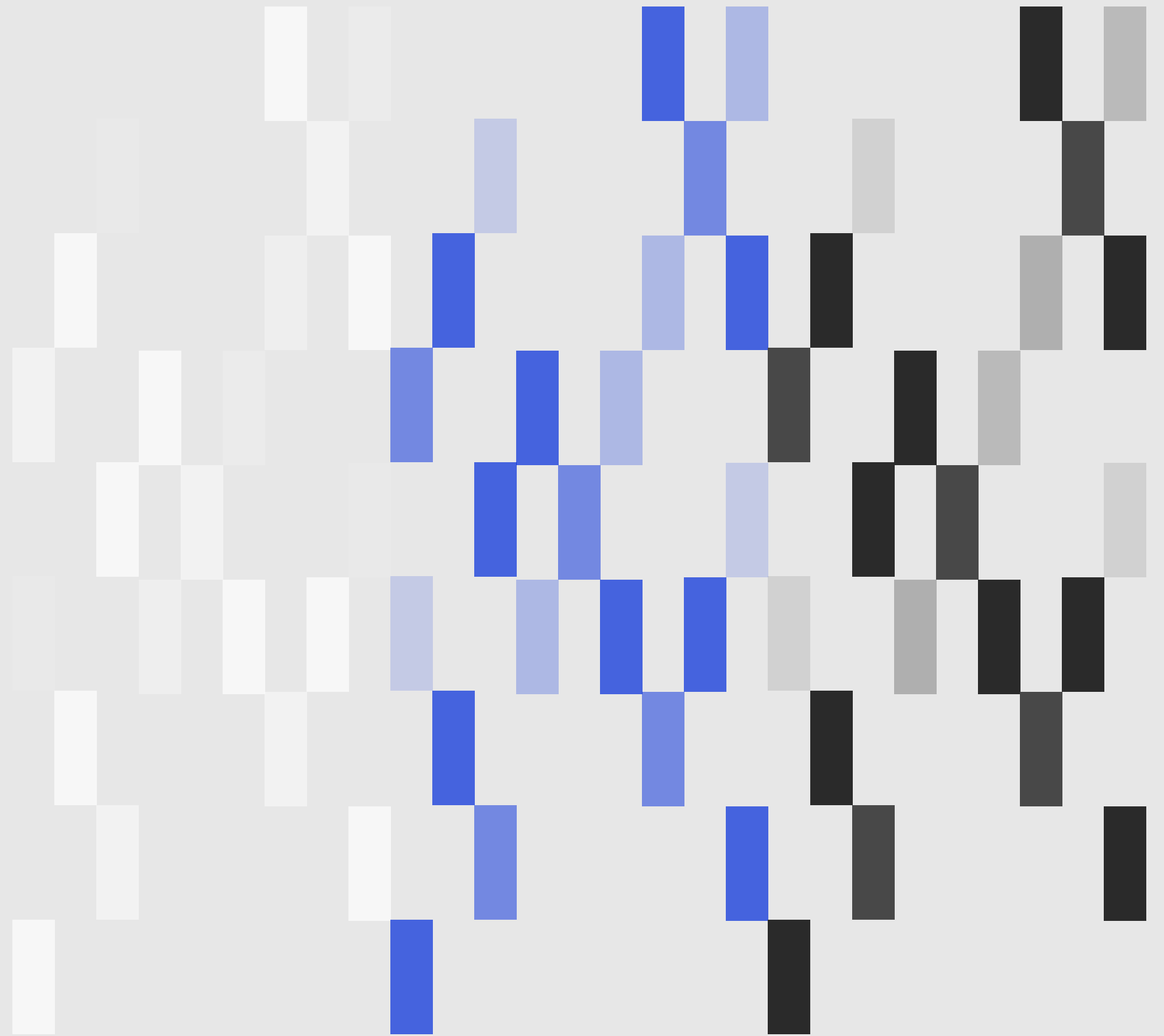
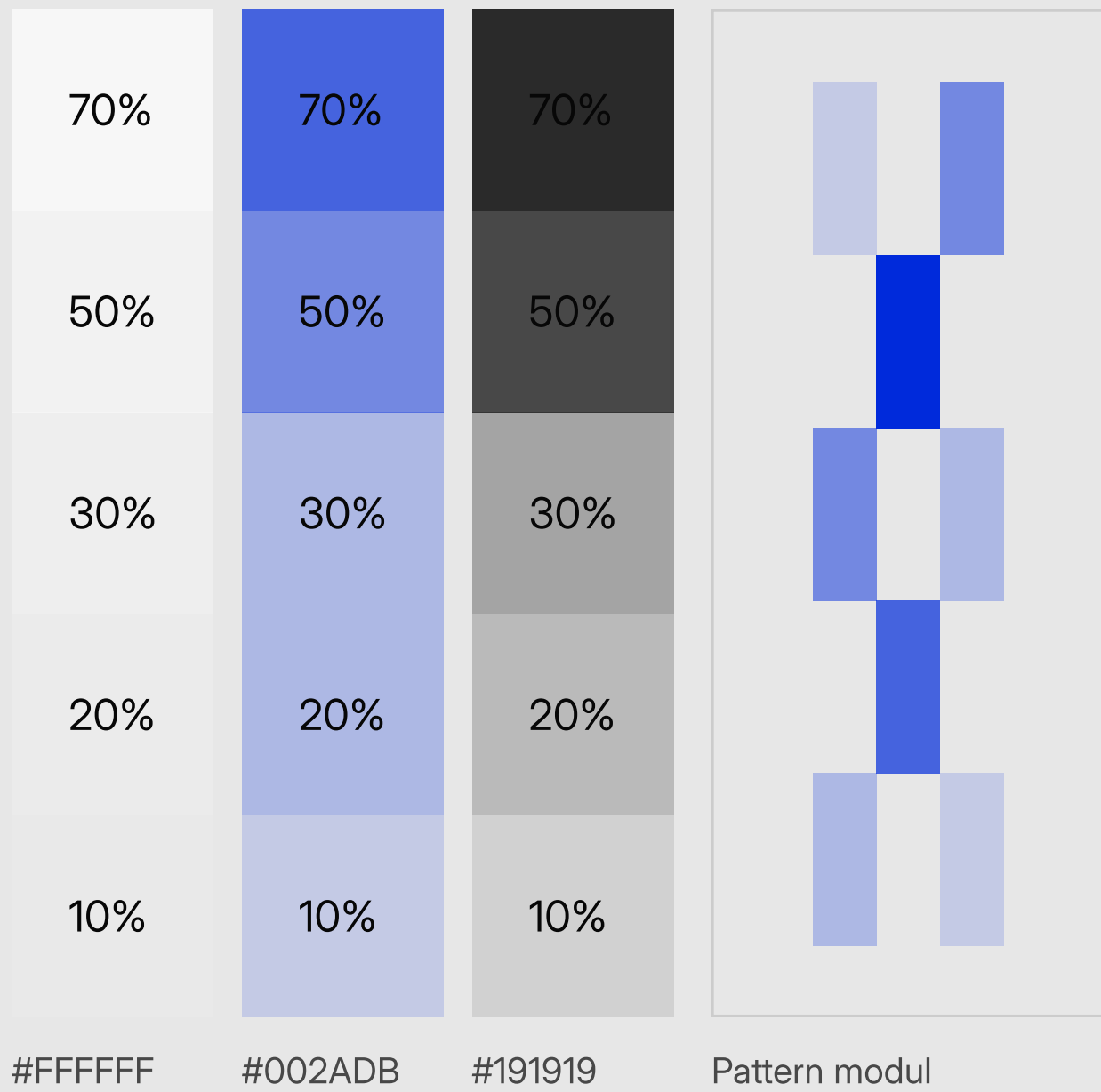

# Logo and pattern placement

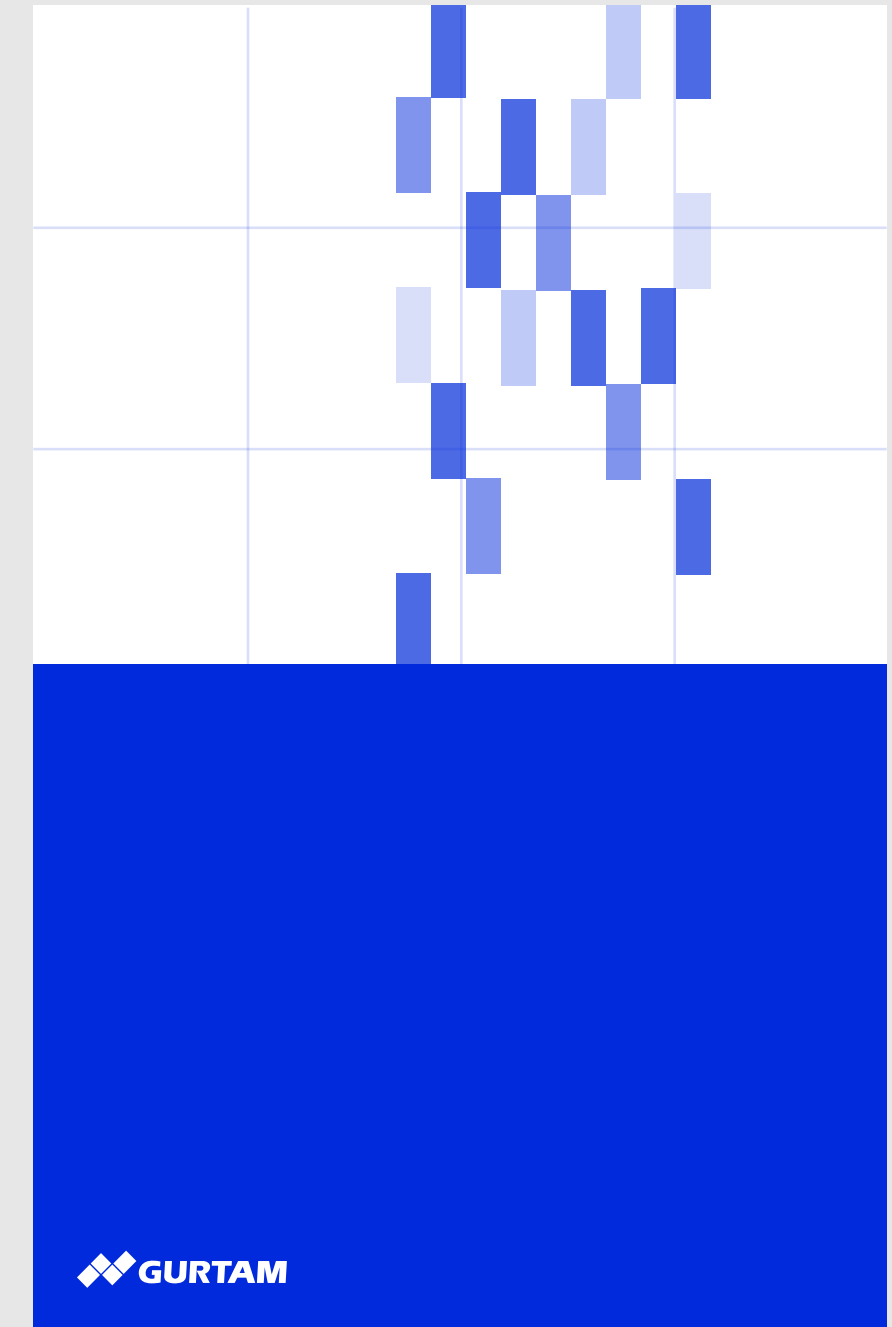
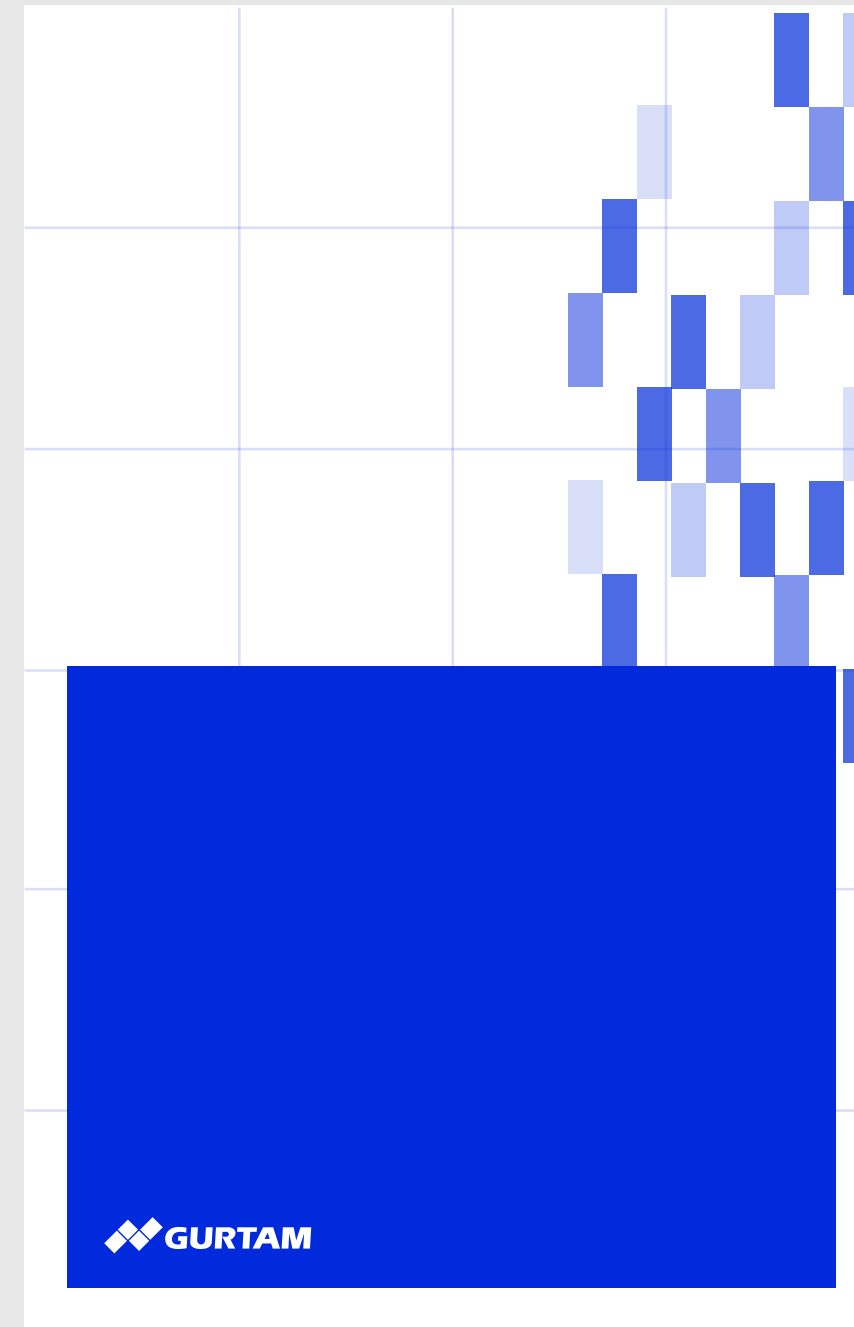
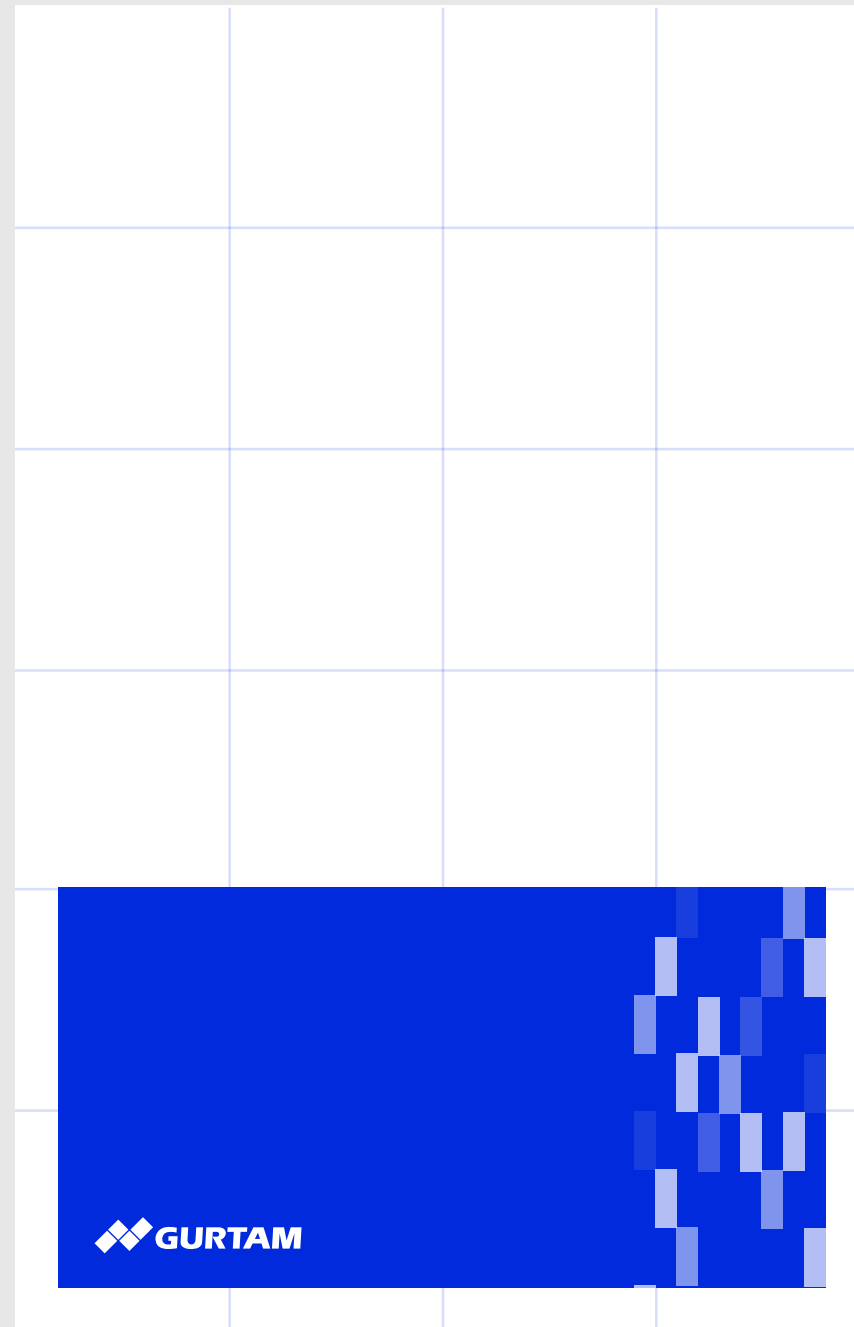
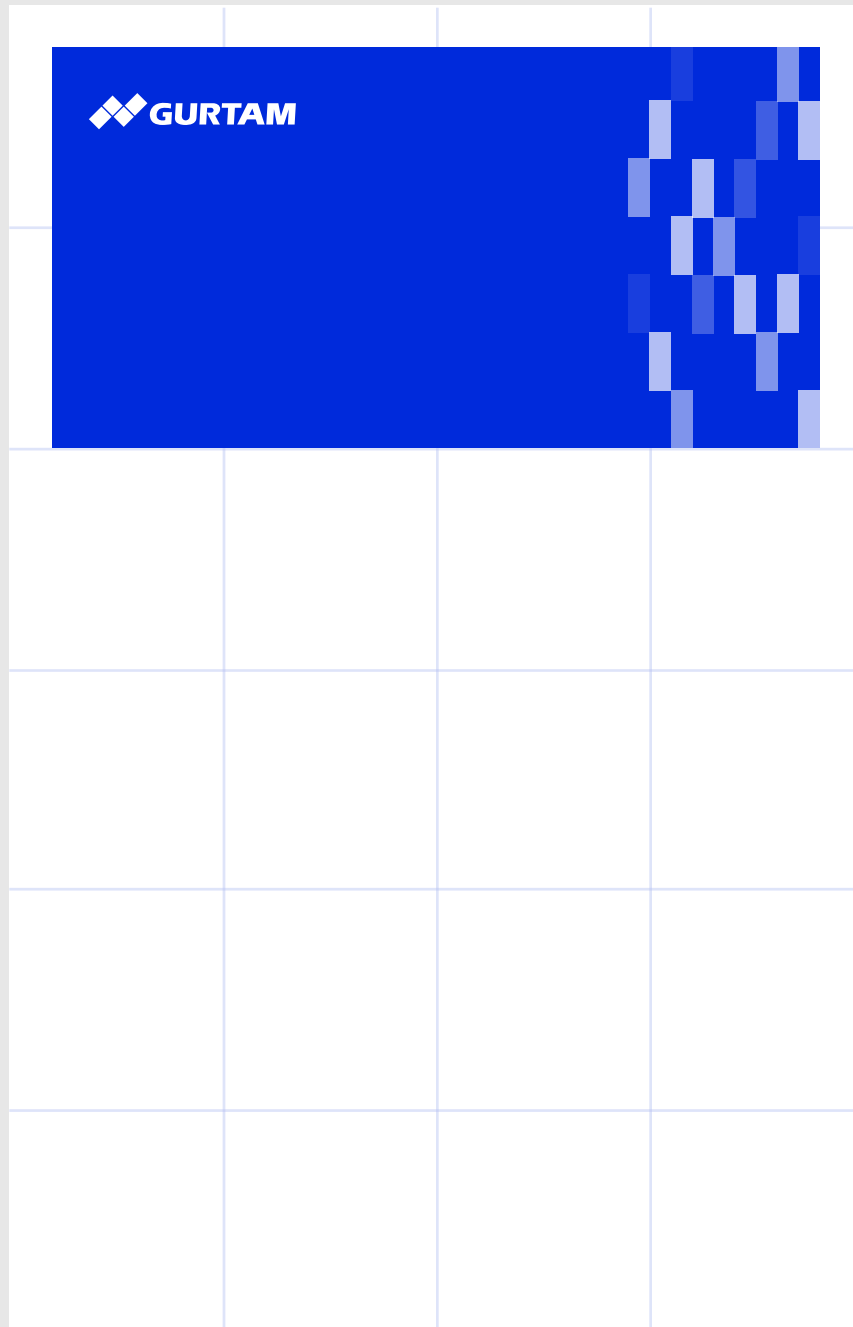

Don't place the logo on complex images and photographs

# Grid construction

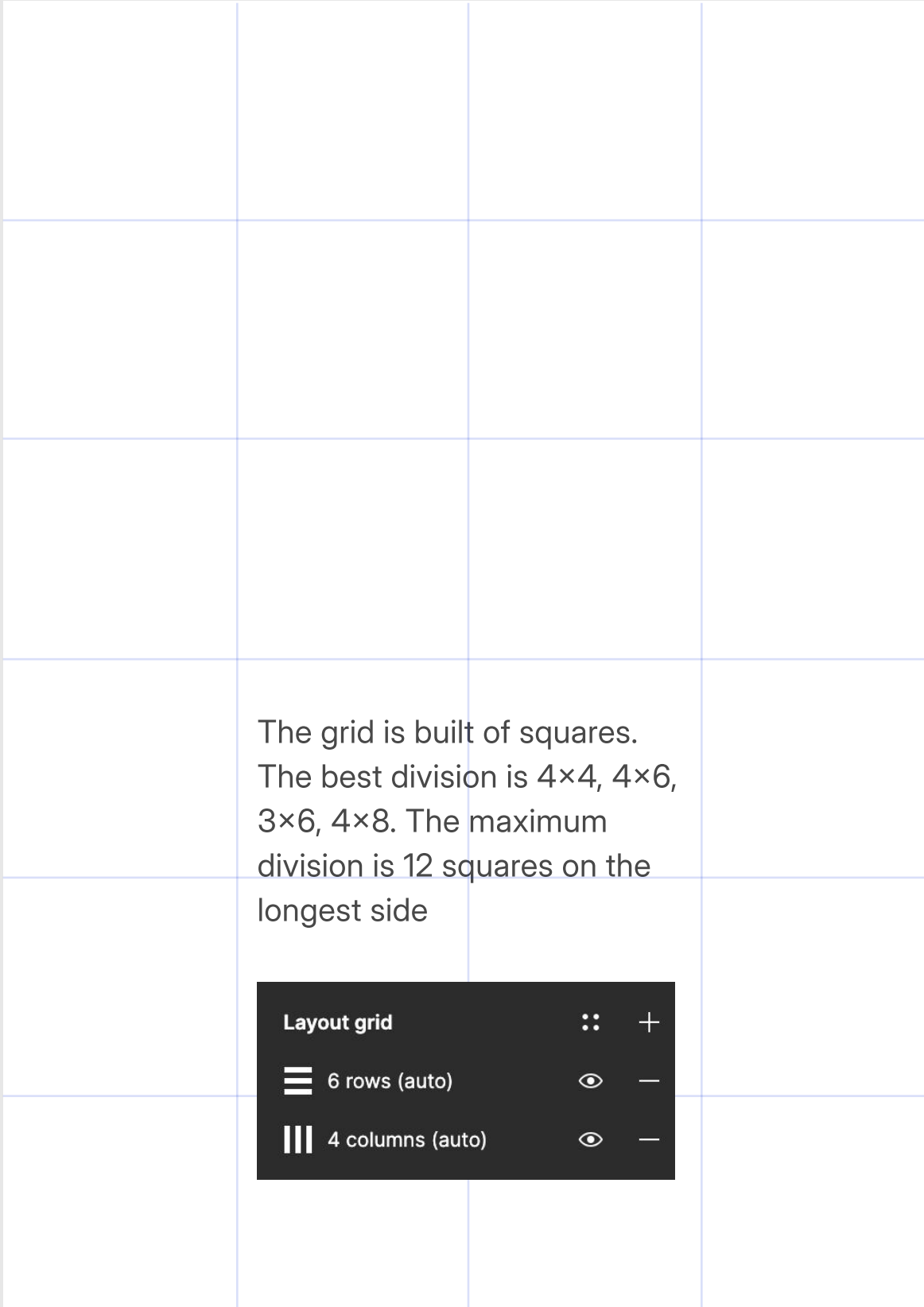

The grid is built of squares. The best division is 4×4, 4×6, 3×6, 4×8. The maximum division is 12 squares on the longest side

Layout grid	⋮	+
☰ 6 rows (auto)	👁	—
☷ 4 columns (auto)	👁	—

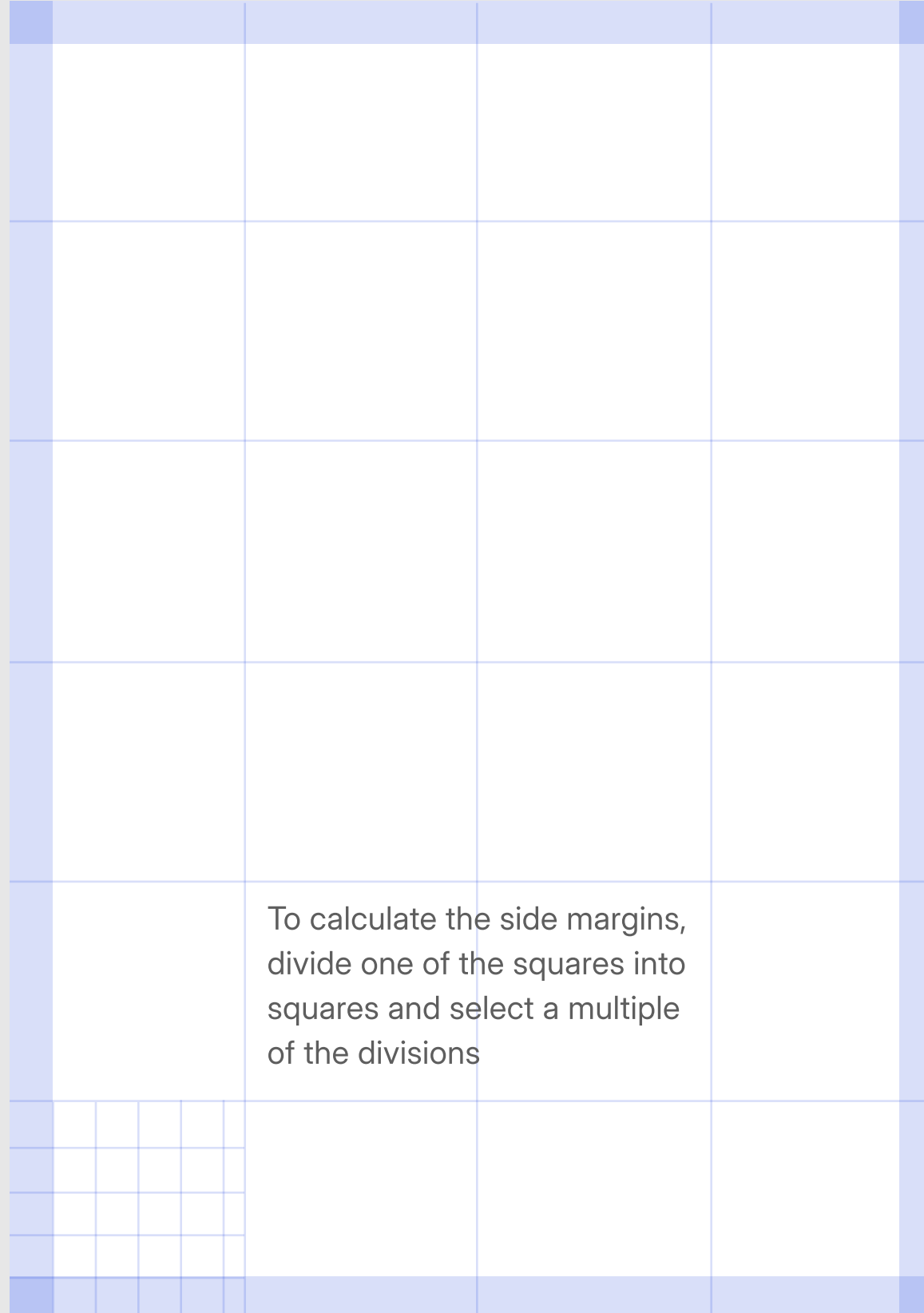

To calculate the side margins, divide one of the squares into squares and select a multiple of the divisions

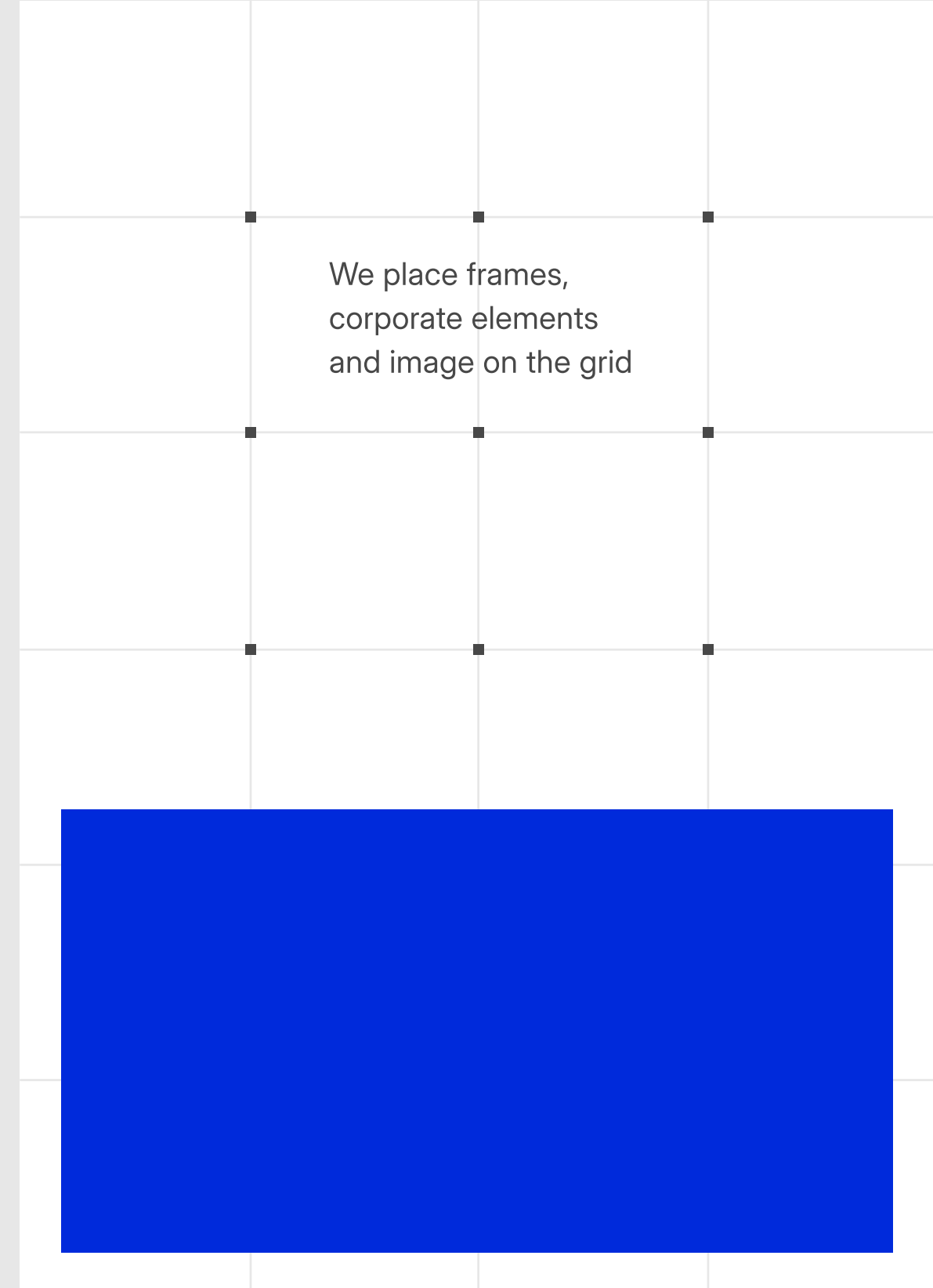

We place frames, corporate elements and image on the grid

**Gurtam exists to bring telematics technology closer to people and businesses.**



**GURTAM** [www.gurtam.com](http://www.gurtam.com)



**Gurtam exists to bring telematics technology closer to people and businesses.**

The square is being introduced into all the company's media, changing them to fit the overall style.

**GURTAM** [www.gurtam.com](http://www.gurtam.com)

**Gurtam exists to bring telematics technology closer to people and businesses.**

The square is being introduced into all the company's media, changing them to fit the overall style.

The square is being introduced into all the company's media, changing them to fit the overall style. The square is being introduced into all the company's media, changing them to fit the overall style.

The square is being introduced into all the company's media, changing them to fit the overall style. The square is being introduced into all the company's media, changing them to fit the overall style.

The square is being introduced into all the company's media, changing them to fit the overall style. The square is being introduced into all the company's media, changing them to fit the overall style.

**GURTAM** [www.gurtam.com](http://www.gurtam.com)

Don't place the logo on complex images and photographs

# Illustration style

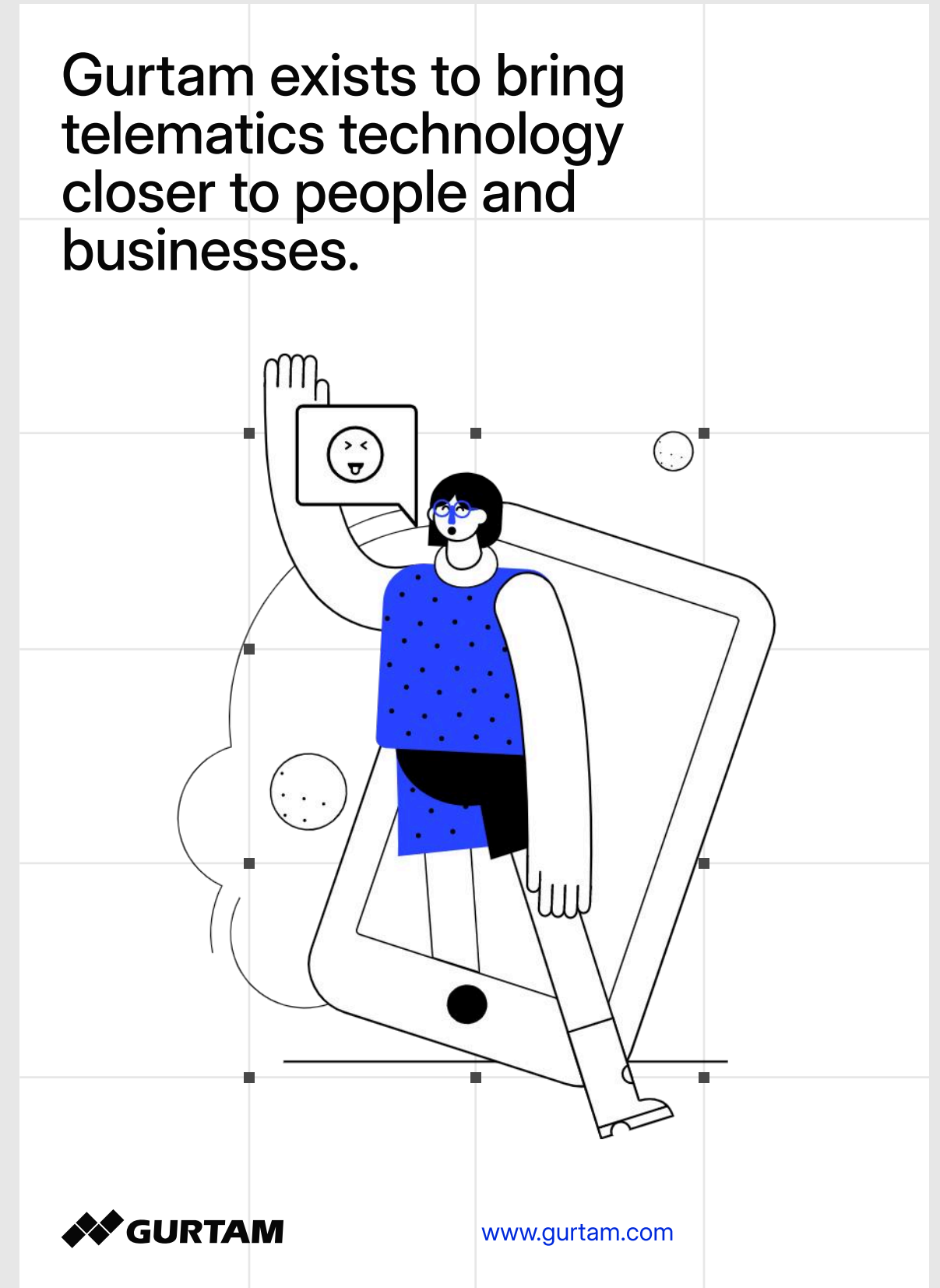
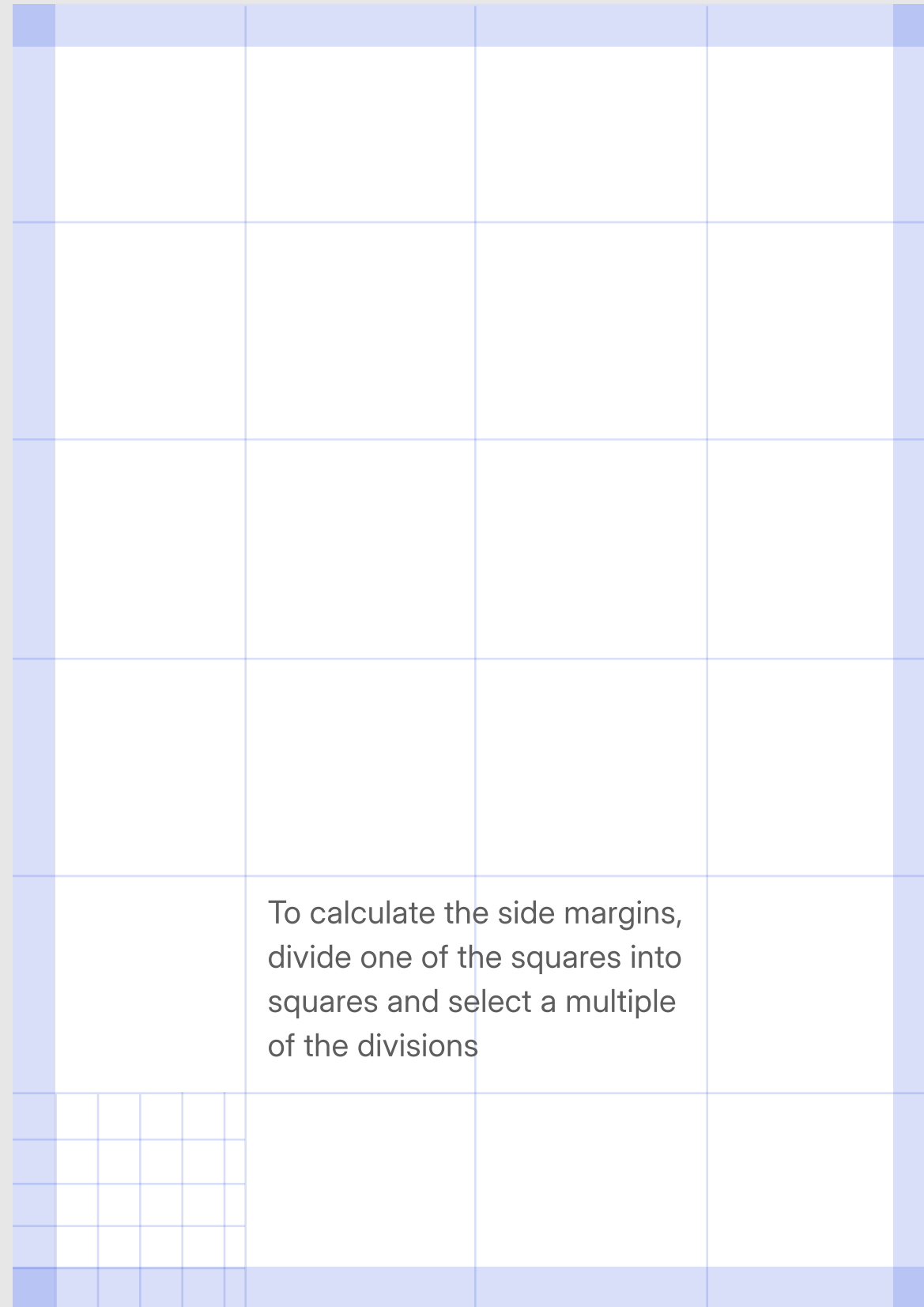
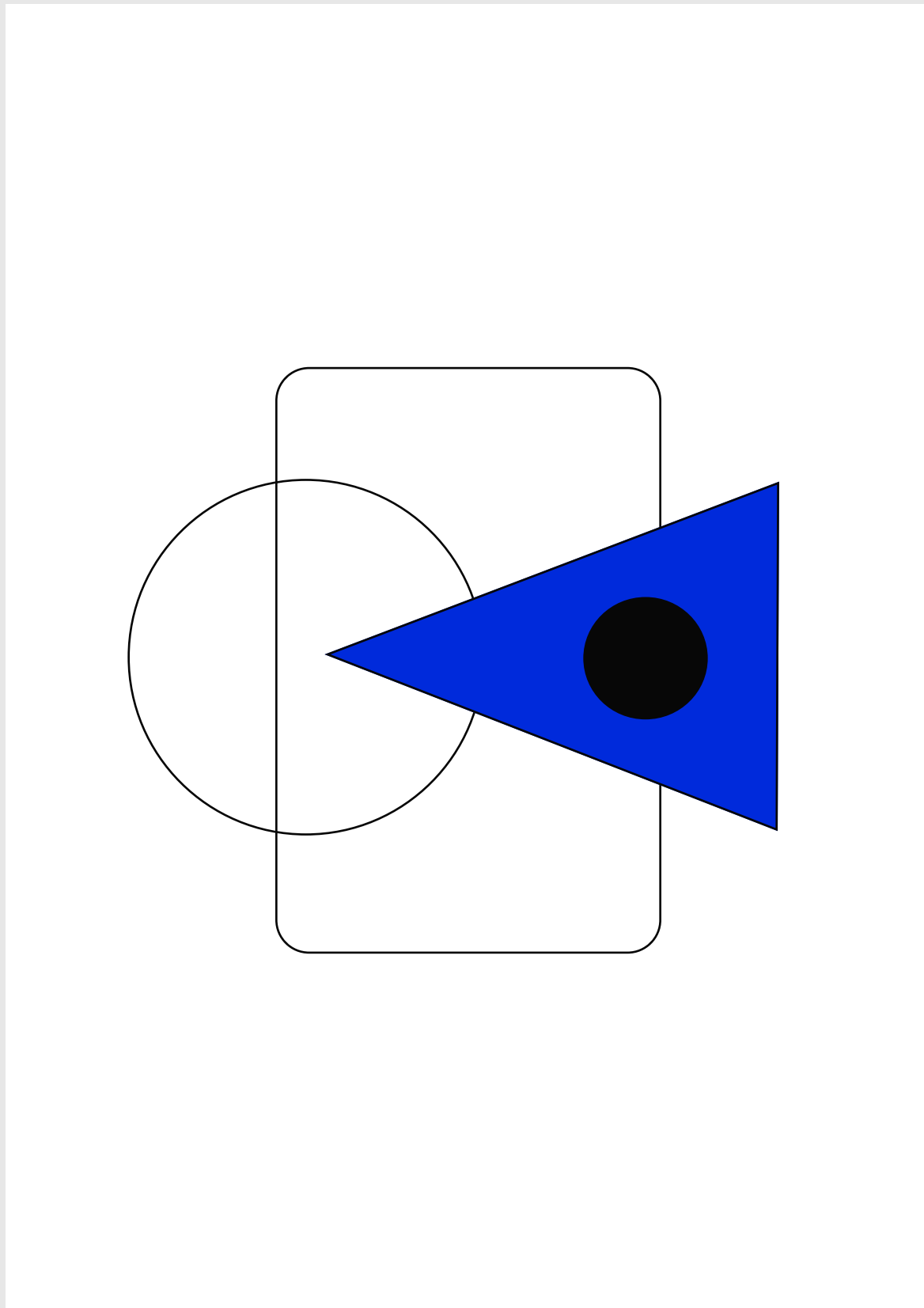

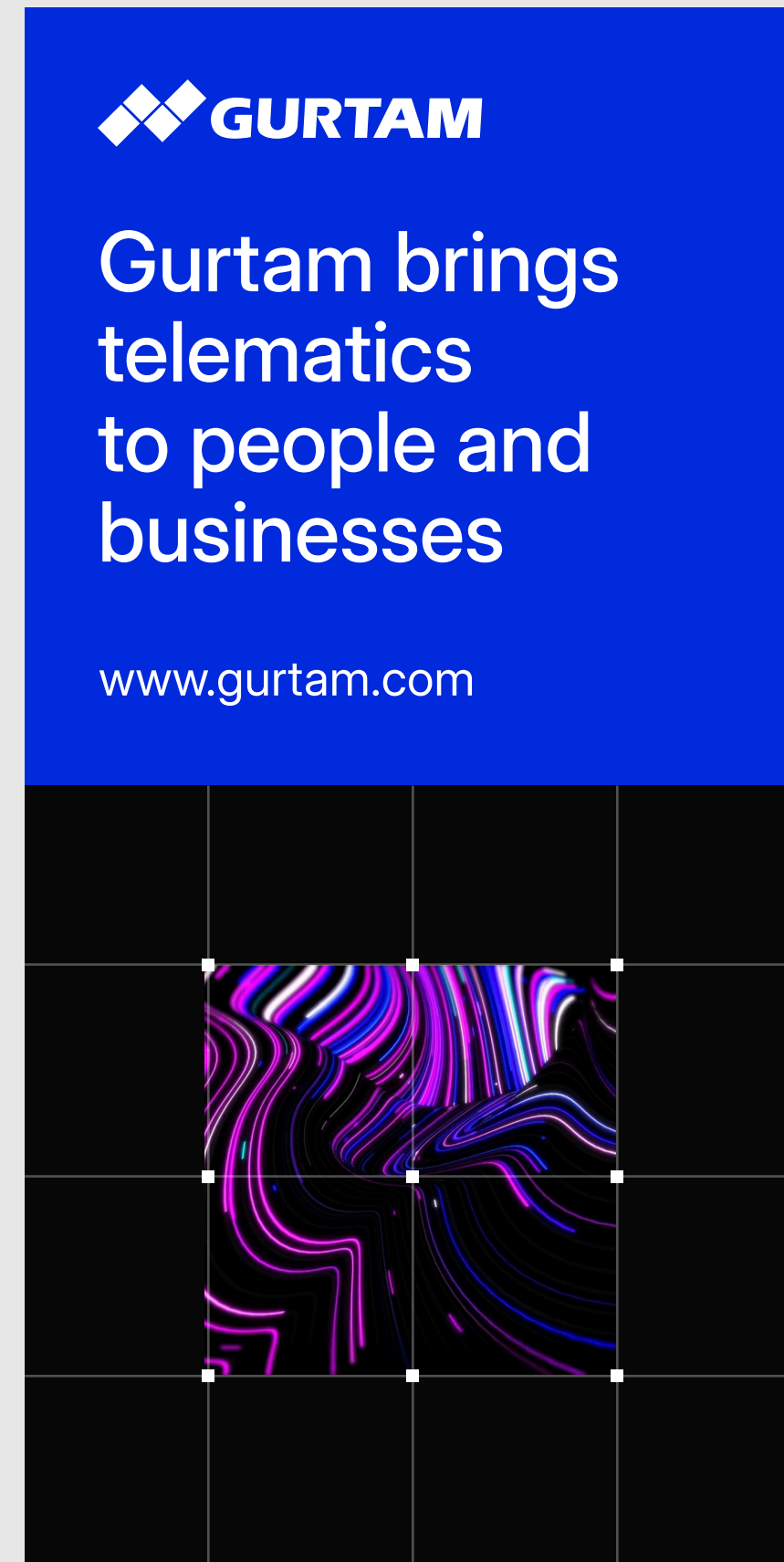
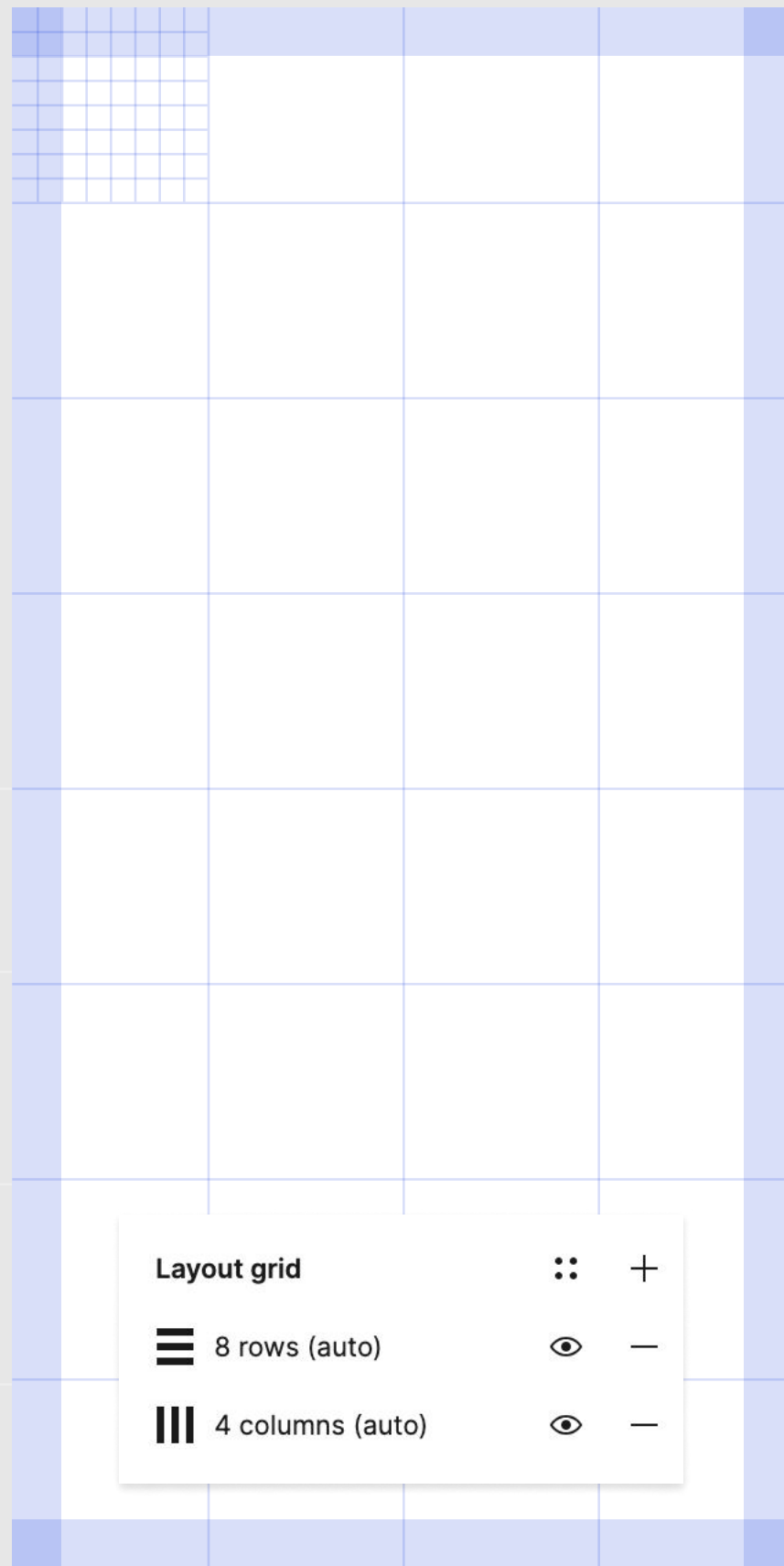



Employer brand

# ART GURTAM PEOPLE

The square is being introduced into all the company's media, changing them to fit the overall style.

The square is being introduced into all the company's media, changing them to fit the overall style.

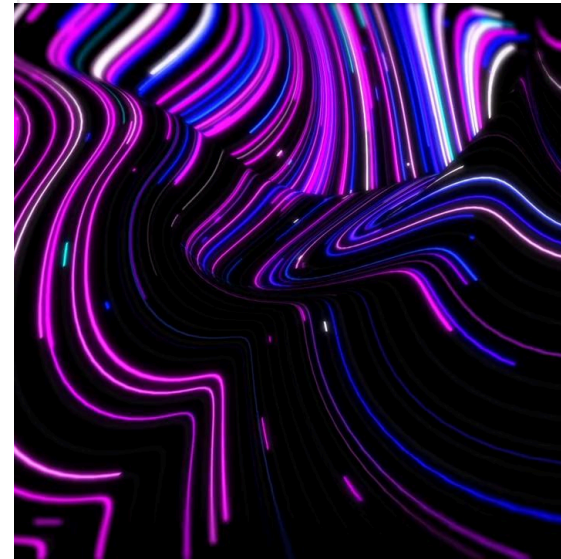
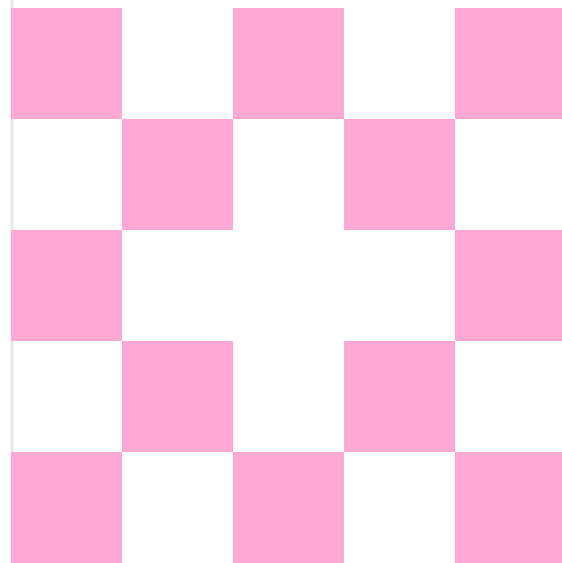

The square is being introduced into all the company's media, changing them to fit the overall style.



Employee corporate font

ABCDEFGH  
IJKLMNOP  
QRSTUVWXYZ

Pattern

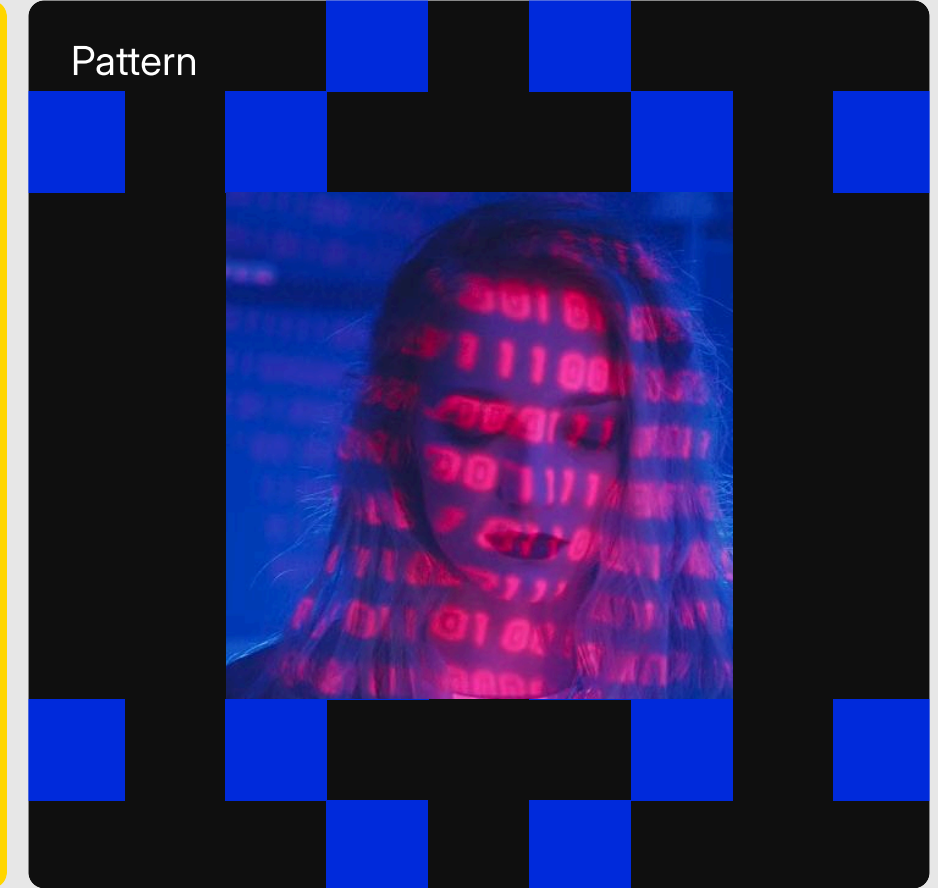

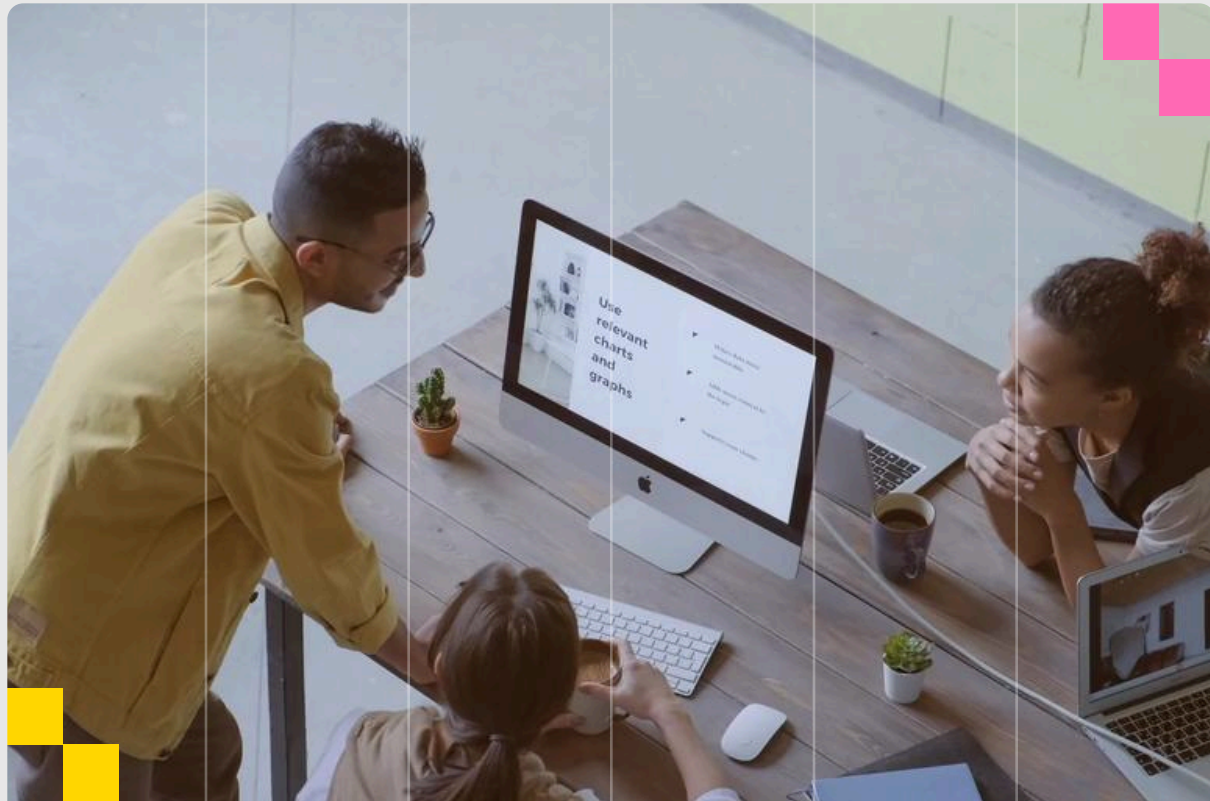
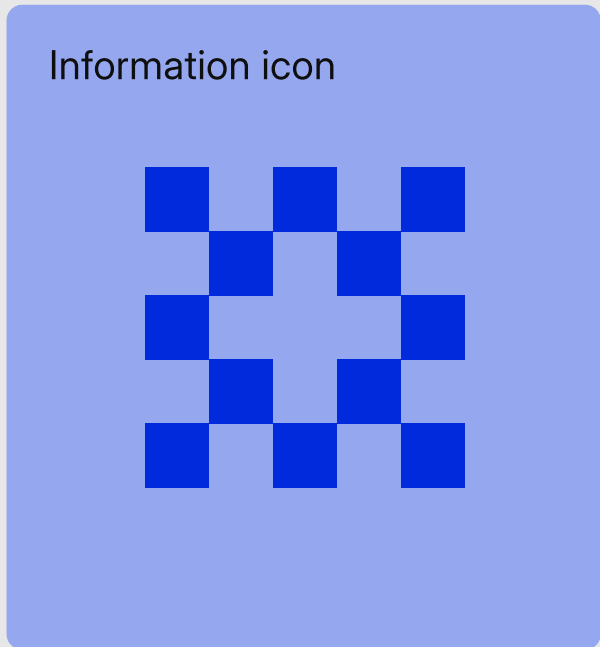
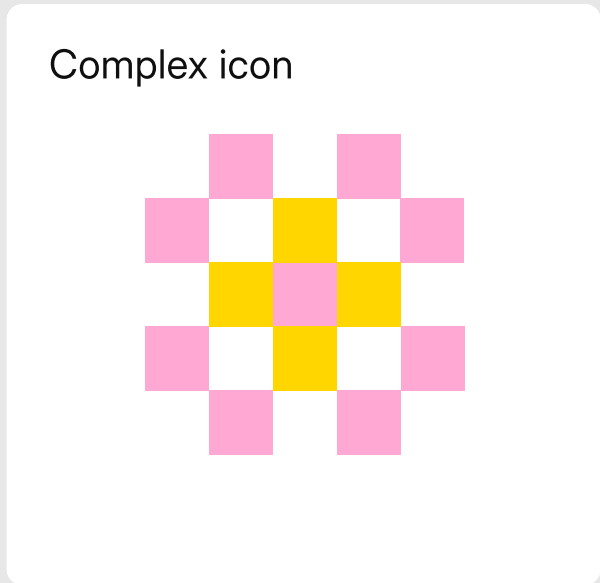
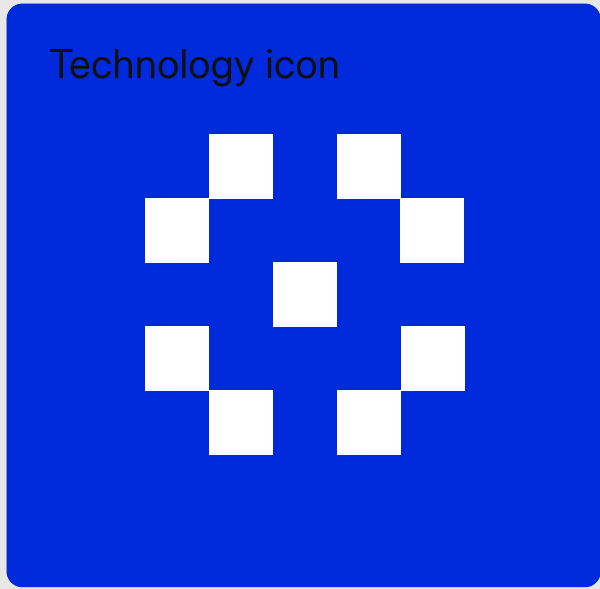

**GURTAM EXISTS TO BRING  
TELEMATICS TECHNOLOGY CLOSER  
TO PEOPLE AND BUSINESSES.**

**1**  
The square is being introduced into all the company's media, changing them to fit the overall style.

**2**  
The square is being introduced into all the company's media, changing them to fit the overall style.

**3**  
The square is being introduced into all the company's media, changing them to fit the overall style.

**4**  
The square is being introduced into all the company's media, changing them to fit the overall style.



**GURTAM EXISTS TO  
BRING TELEMATICS  
TECHNOLOGY CLOSER  
TO PEOPLE AND  
BUSINESSES.**

The square is being introduced into all the company's media, changing them to fit the overall style.

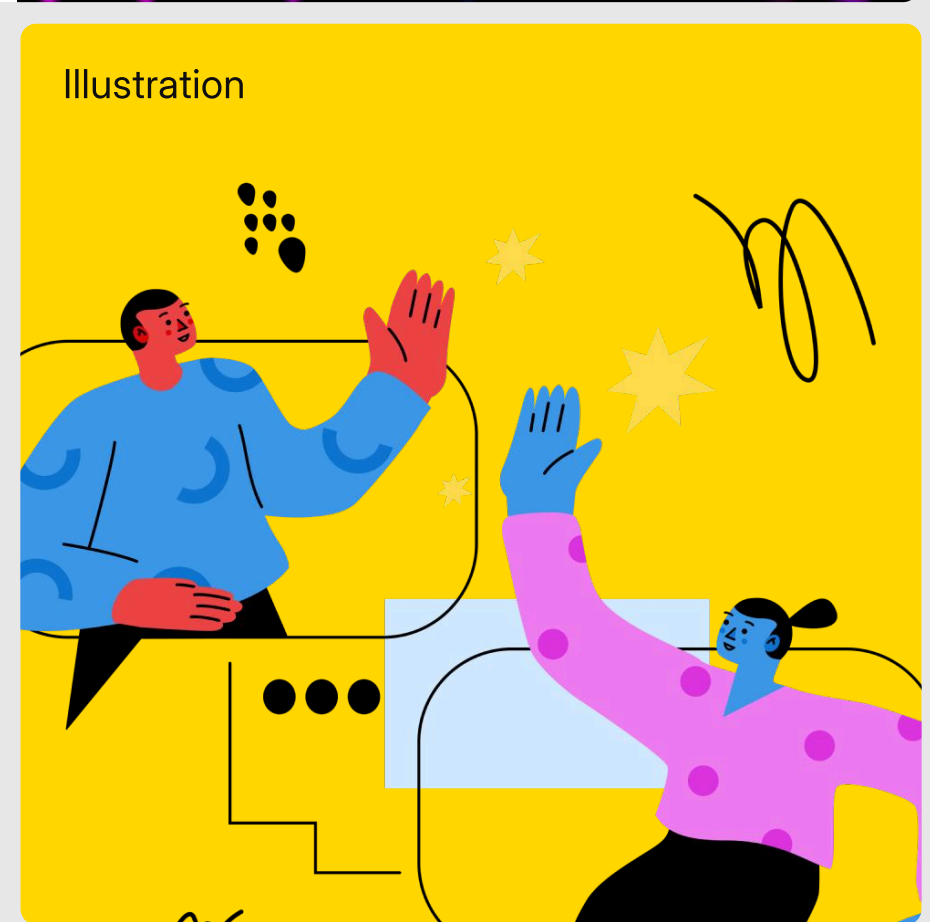
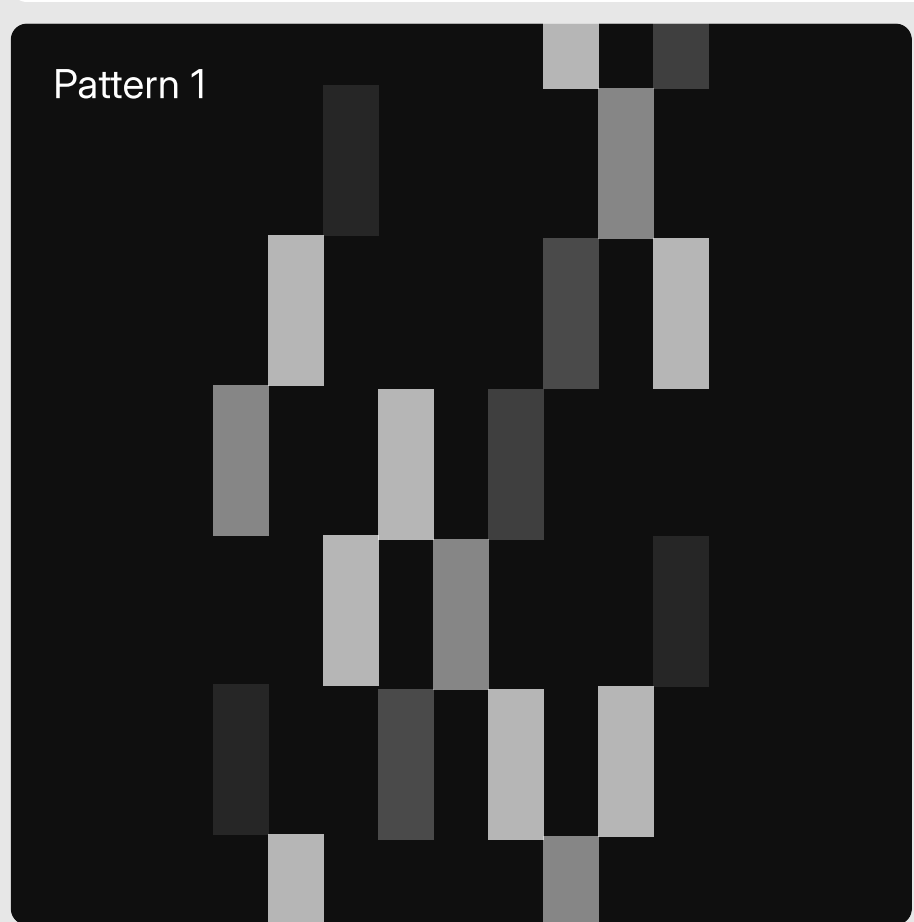

Alternative font for Employer brand and internal communications

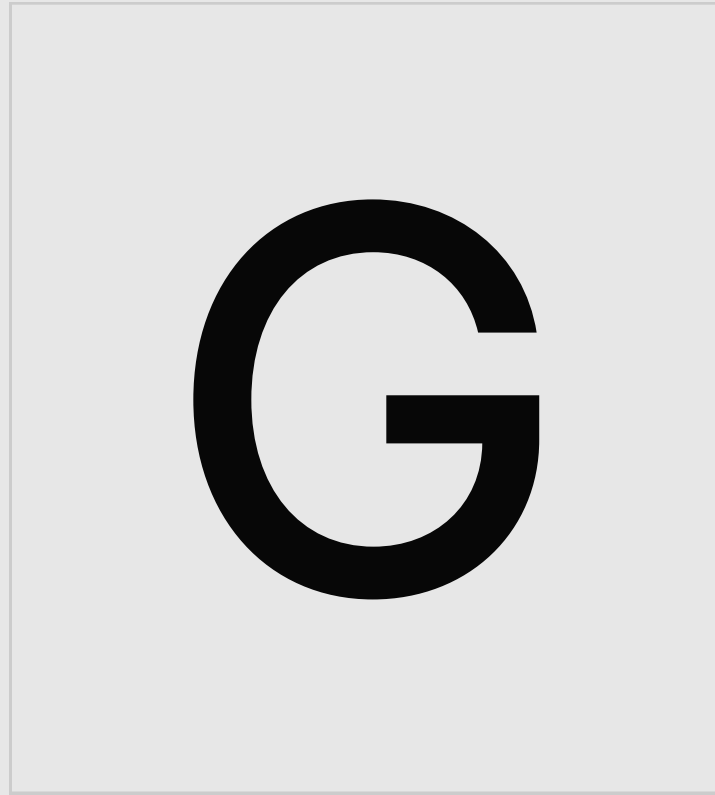

Inter Display

**GURTAM PEOPLE**

Rotonto Regular

**GURTAM PEOPLE**



# Grid construction

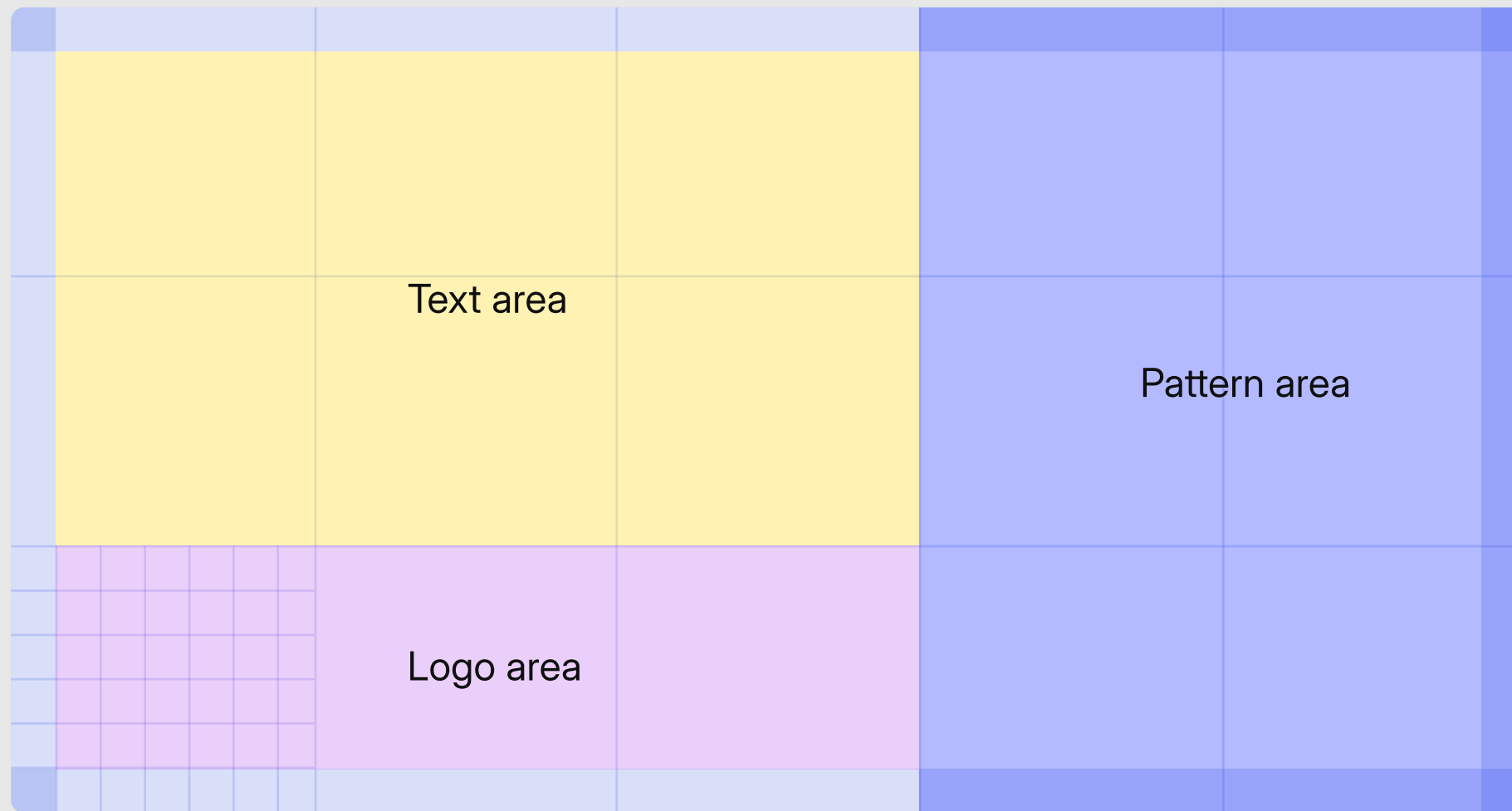

# Illustration style

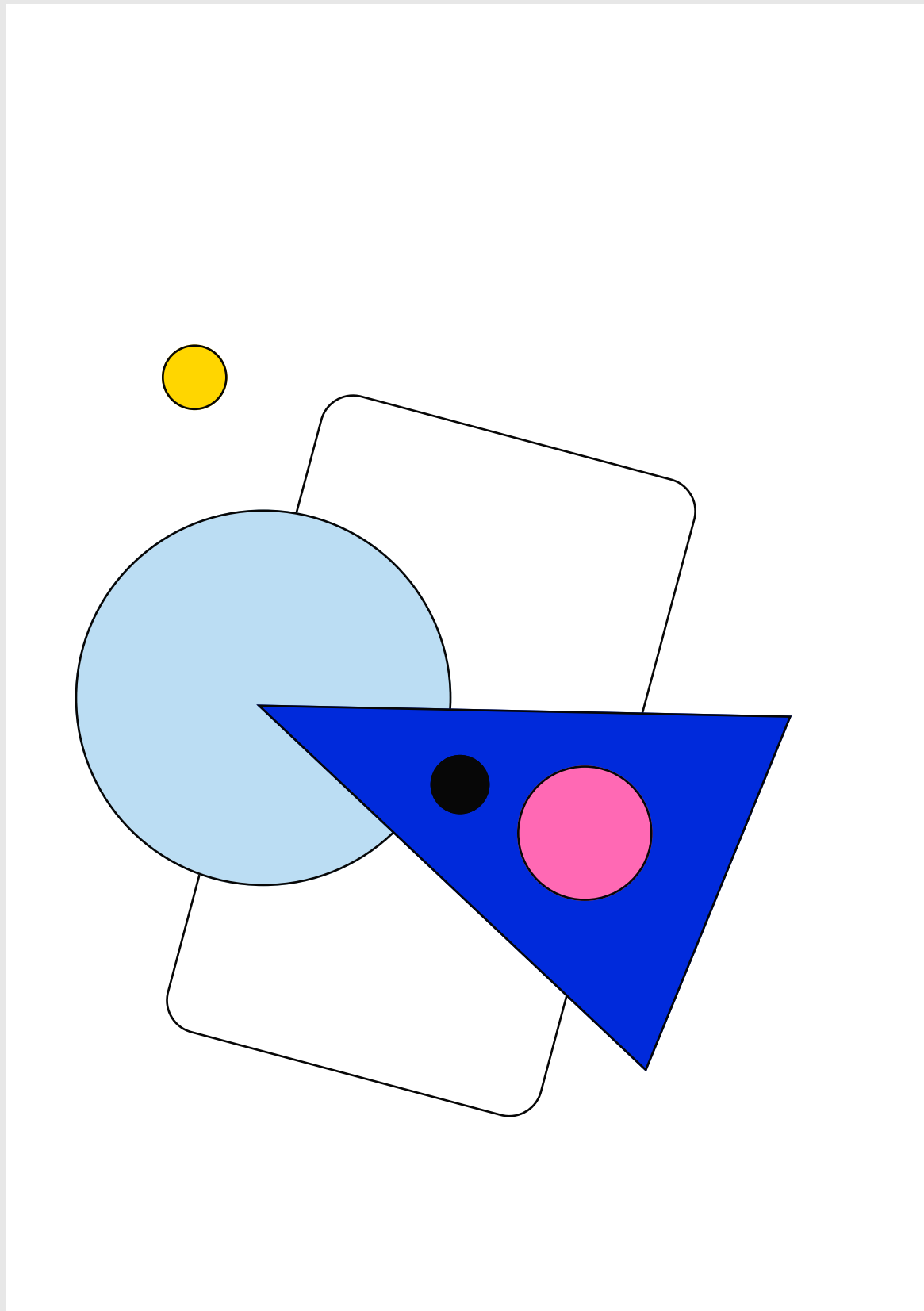

Employer identity

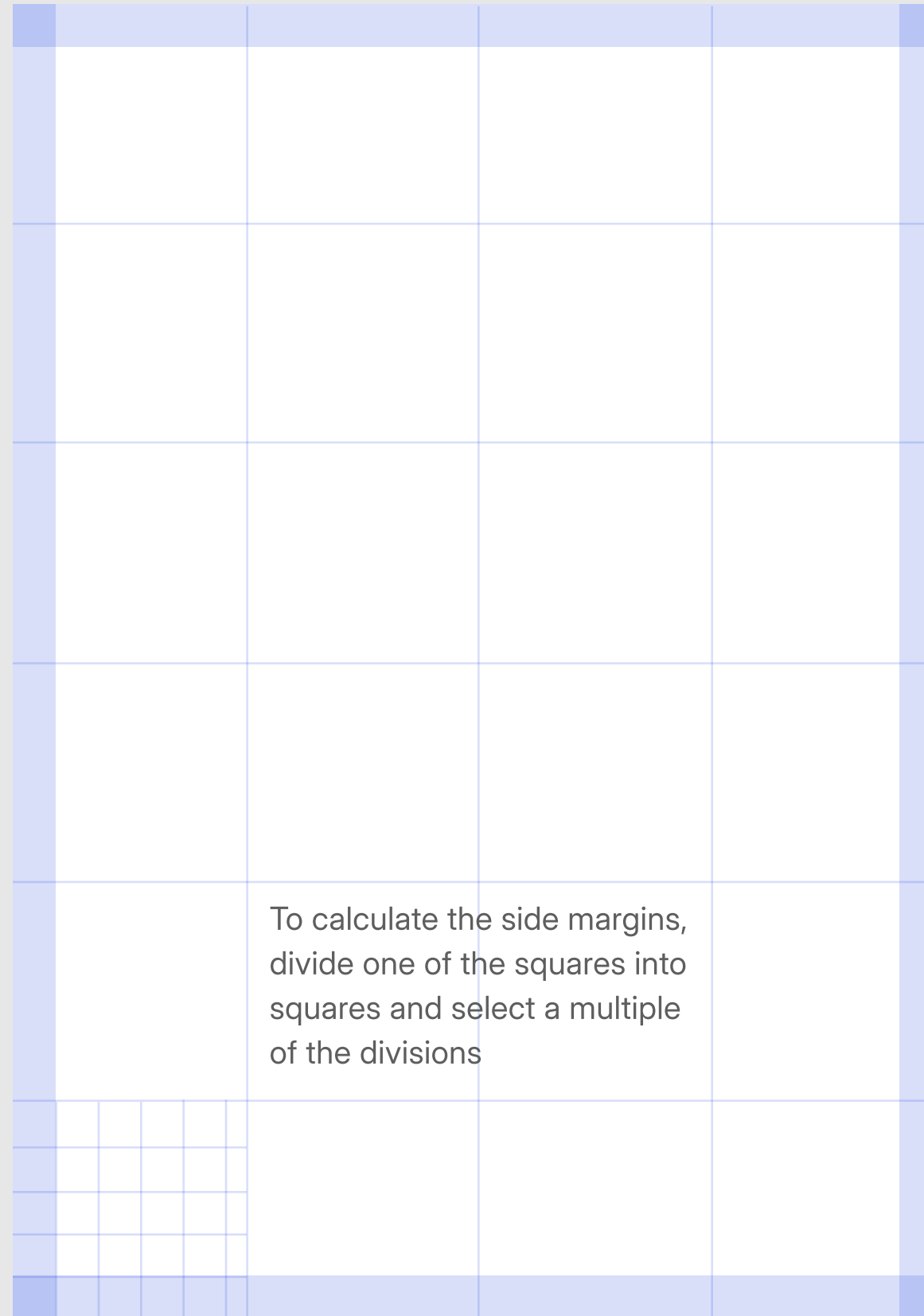

Brand guidelines



Gurtam



**DEVELOPMENT  
TEAM LEAD**

Engineering Lithuania (Vilnius) Hybrid

**Your role**

Lead a small team developing in Python - whereas we also think positively of adding full-stack JS stack, implementing and maintaining AI tools for virtual assistants tailored to internal processes.

 [www.gurtam.com](http://www.gurtam.com)



**DEVELOPMENT  
TEAM LEAD**

Engineering Lithuania (Vilnius) Hybrid

**Your role**

Lead a small team developing in Python - whereas we also think positively of adding full-stack JS stack, implementing and maintaining AI tools for virtual assistants tailored to internal processes.

 [www.gurtam.com](http://www.gurtam.com)

# Booth template

Reception 1600×750×75 mm

Booth 5000×10000 mm

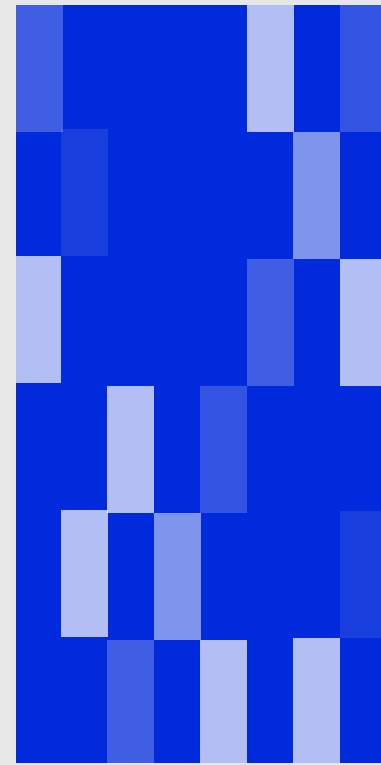
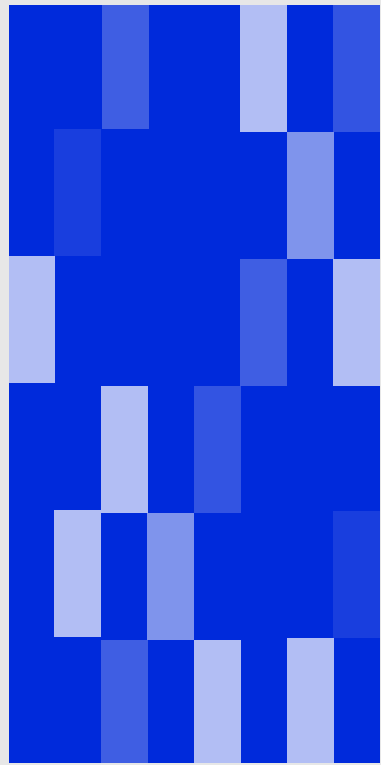

Left side

Right side



# GURTAM HACKATHON

# 14:00 23.06

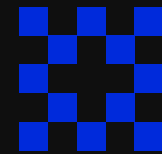

The square is being introduced into all the company's media, changing them to fit the overall style.

The square is being introduced into all the company's media, changing them to fit the overall style.



[www.gurtam.com](http://www.gurtam.com)

